

Cromie collection _ *vol. I*

the voyage diaries



Bellotti Ezio

Cromie collection_ *vol.1*

the voyage diaries



Bellotti Ezio



La bellezza del passato immersa nella contemporaneità ispira la nuova collezione Cromie, che si racconta in un diario di viaggio, compiuto attraverso le magnifiche scenografie dei panorami italiani, in uno scambio continuo di emozioni e colori. Stresa, sul lago Maggiore, la prima meta.

Si respira il fascino della scoperta, la vivacità della Belle Époque, la grazia della natura. Stresa, meta di intellettuali e aristocratici europei che fin dall'800 vi soggiornavano nel corso dei loro *Grand Tour*, conserva quel glorioso passato nelle sue architetture, affacciate sul Golfo Borromeo. Luoghi di memoria, di cultura e di incanto. Da questo orizzonte emerge Villa Frua, un gioiello dal carattere Liberty incastonato fra l'azzurro e il verde del paesaggio. Una dimora che dona nuove suggestioni divenendo pittoresco teatro della collezione Cromie.

☞ *“È il luogo più voluttuoso che io abbia mai visto al mondo. La natura incanta con mille seduzioni sconosciute e ci si sente in uno stato di rara sensualità e raffinatezza”.*

Gustave Flaubert, sul Lago Maggiore.

The beauty of the past set in the modern world is the inspiration for the new Cromie collection, which is recounted in a travel diary, filled with magnificent scenes of Italian landscapes with constantly changing emotions and colours. Stresa, located on the shores of Lake Maggiore, is our first destination.

Here, you can immerse yourself in the thrill of discovery, the vivaciousness of the Belle Époque, the elegance of nature. Stresa, overlooking the Borromean gulf, was a destination of European intellectuals and aristocrats who had stayed there during their *Grand Tour* since the 19th century. It retains its glorious past in its architecture, with places of remembrance, culture and charm. From this horizon, the Villa Frua emerges, a jewel of the Liberty nature nestled between the blue and the green of the landscape. A residence which provides new grandeur is the picturesque backdrop for the Cromie collection.

Bellotti Ezio is forging a path of harmony and balance between heritage and innovation. Its classic spirit presented with a modern appeal, its moods becoming glamorous, its nuances colourful and graceful. Writing a new chapter of its history.

☞ *"It is the most voluptuous place I have ever seen in the world. Nature enchants with a thousand unknown seductions and one feels in a state of rare sensuality and refinement".* **Gustave Flaubert, writing about Lake Maggiore.**





Bellotti Ezio intraprende un percorso di armonia ed equilibrio fra heritage e innovazione. La sua anima classica si veste di moderno appeal, le sue atmosfere si fanno glamour, le sue nuance variopinte e leggiadre. Per scrivere un nuovo capitolo della sua storia.



Art. 4010

Divano a 3 posti
3 seat sofa
cm 275 * 125 * h 90

Art. 4014

Tavolino laterale
Side table
cm 70 * 70 * h 61



Art. 4014
Tavolino laterale
Side table
cm 70 * 70 * h 61





Art. 4013
Tavolino centrale
Coffee table
cm 145 * 89 * h 47



Art. 4997
Poltrona intagliata
Carved armchair
cm 75 * 87 * h 99





Art. 4996
Poltrona intagliata
Carved armchair
cm 75 * 87 * h 99

Art. 4998
Tavolino centrale
Coffee table
cm 143 * 83 * h 44





Art. 5765
Secretaire intarsiato
Inlaid secretaire
cm 131 * 58 * h 200





Art. 5765
 Secrétaire intarsiato
 Inlaid secrétaire
 cm 131 * 58 * h 200



Art. 5380

Specchiera intagliata
Carved frame with mirror
cm 142 * h 235





Art. 4931
Poltrona intagliata
Carved armchair
cm 87 * 92 * h 101

Art. 4935
Tavolino laterale
Side table
cm 71 * 71 * h 56

Art. 9022
Poltroncina intagliata
Carved armchair
cm 60 * 63 * h 103





Art. 1371

Vetrina intarsiata
Glass cabinet inlaid
cm 137 * 54 * h 222

Art. 1373

Tavolo da pranzo
Dining table
cm Ø 130 * h 78

Art. 1376

Sedia intagliata
Carved chair
cm 50 * 59 * h 103



Art. 1371
Vetrina intarsiata
Glass cabinet inlaid
cm 137 * 54 * h 222





Art. 1370
 Credenza a 4 ante
 intarsiata
*Sideboard with
 4 doors inlaid*
 cm 236 * 60 * h 95









Art. 3710
 Letto con testata
 intagliata
*Bed with carved
 headboard*
 cm 215 * 210 * h 192

Art. 3714
 Comodino con
 elementi intagliati
*Bedside table with
 carved elements*
 cm 72 * 43 * h 66



Art. 3712

Comò con
elementi intagliati
*Chest of drawers with
carved elements*
cm 142 * 55 * h 93

Art. 3716

Specchiera intagliata
Carved frame with mirror
cm 71 * h 100





Art. 3715

Toilette con
elementi intagliati
*Dressing table with
carved elements*
cm 142 * 53 * h 80

Art. 3717

Sedia intagliata
Carved chair
cm 53 * 55 * h 104





Metaphors of modernity and lightness. Mandarin and Anise are the intense palettes providing colours for the Cromie collection. Two vibrant and joyous shades expressed in the colours of the rainbow running through the different settings, in harmony with the soft nuances of Villa Frua.

Metafore di modernità e leggerezza. Mandarino e Anice sono le intense palette che dipingono la collezione Cromie. Due tonalità vibranti e gioiose espresse in un arcobaleno di sfumature che percorre le differenti ambientazioni, in armonia con le tenui nuance di Villa Frua.

- 1** lucidato noce canaletto con decori bronzati e laccato mandarino
canaletto walnut polished finish with bronzed varnish and lacquered mandarin
- 2** velluto
velvet
- 3** tappeto stampato personalizzato
custom printed carpet
- 4** lino jacquard
linen jacquard
- 5** laccato spelato mandarino
lacquered brushed mandarin
- 6** passamanerie
trimmings
- 7** marmo Onice Miele
marble Honey Onyx
- 8** essenza ebano
ebony veneer
- 9** velluto
velvet
- 10** lino chevron jacquard
chevron linen jacquard
- 11** micropattern jacquard
micropattern jacquard
- 12** damasco jacquard
damask jacquard
- 13** finitura a foglia Silver Gold
leaf finish Silver Gold

Una tavolozza calda, avvolgente, ma anche contemporanea e decisa. Il moodboard Mandarinino è un omaggio alle tonalità della terra e alla sua matericità tattile e visiva. Tappeti, velluti, filati, si sposano al massello di noce, alle finiture Silver Gold e alla nuova finitura laccato spelato. Tessuti a tinta unita si affiancano a rivisitazioni moderne di motivi broccati e a fantasie astratte, che donano un look inedito e glamour agli arredi dall'animo classico.

A warm palette, enchanting, but also modern and bold. The Mandarin moodboard is a homage to the hues of the Earth and its tactile and visual texture. Carpets, velvets, yarns, blend with solid walnut, Silver Gold finishes and new brushed lacquer finish. Mono-coloured fabrics sit alongside modern reinterpretations of brocade motifs and abstract patterns, providing a unique and glamorous look to the furniture with a classic soul.

Mandarino

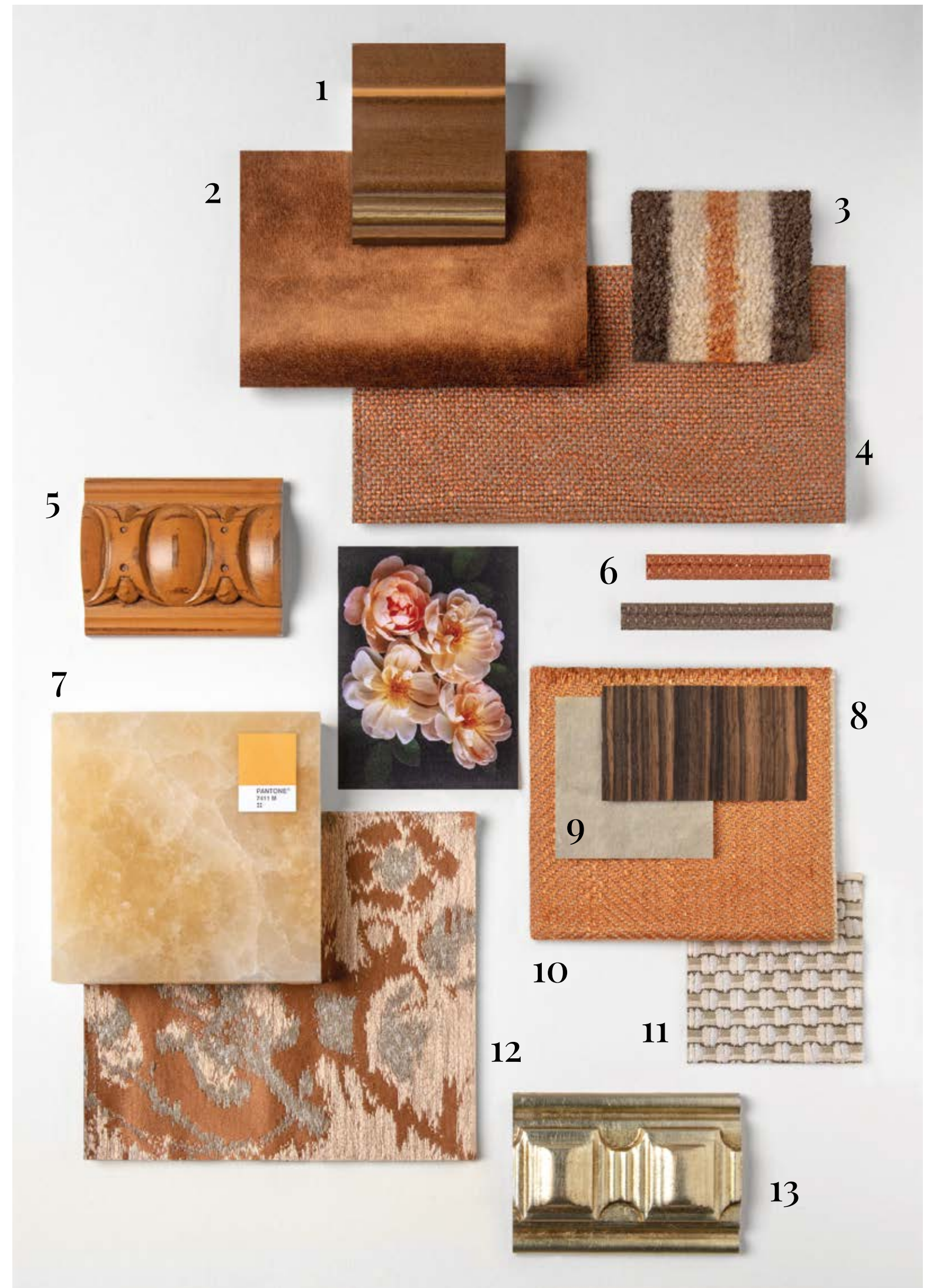

- 1** decoro floreale dipinto a mano
handmade painted floral decoration
- 2** tappeto stampato personalizzato
custom printed carpet
- 3** finitura a foglia Silver Gold
leaf finish Silver Gold
- 4** riga jacquard
striped jacquard
- 5** passamaneria
trimming
- 6** damasco jacquard
damask jacquard
- 7** broccatello lamè jacquard
lamè brocatelle jacquard
- 8** fregio
ornament
- 9** micropattern jacquard
micropattern jacquard
- 10** laccato anice spelato
lacquered brushed anise
- 11** cotone stampato
toile de jouy
printed cotton toile de jouy
- 12** marmo Rosa
Portogallo Estremoz
marble Rosa Portogallo Estremoz

Morbido, soave, rilassante, il moodboard Anice porta indoor le profondità cristalline dell'acqua e i suoi effetti benefici. Bilanciando perfettamente l'energico Mandarino, questa palette conduce in un universo onirico, a cui partecipano le tonalità naturali dei filati. Anche le finiture sulle essenze si fanno più delicate, come la laccatura opaca spelata, il celeste e l'oro champagne. I tessuti a tinta unita sono accompagnati da motivi floreali e damascati. Per effetti di impalpabile eleganza.

Soft, mild, relaxing, the Anise moodboard brings the depths of crystal-clear water and its beneficial effects to your home. Perfectly balancing the energy of the Mandarin, this palette leads you to a dreamlike universe fashioned by the natural tones of the yarns. Even the finishes on the substances become more delicate, such as brushed matte lacquer, sky blue and champagne gold. The mono-coloured fabrics are accompanied by floral motifs and damasks. For a result of impalpable elegance.



Anice

Catalogo dei prodotti_ *Product catalogue*





Art. 4010

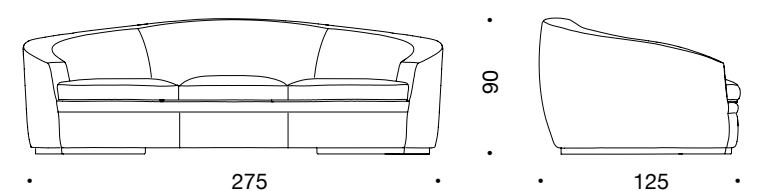

Divano 3 posti in poliuretano espanso indeformabile a densità differenziate e fibra poliestere con struttura interna in legno. Piedi rivestiti in tessuto. Disponibile con rivestimento in tessuto nei colori del campionario. Cuscini decorativi in misto piuma.

Non sfoderabile

3 seater sofa in non-deformable foam polyurethane in different density and polyester fibre with wooden inside structure. Feet covered in fabric. Available covered by fabric as per samples. Decorative cushions with mix feather.

Not removable cover



Art. 4013

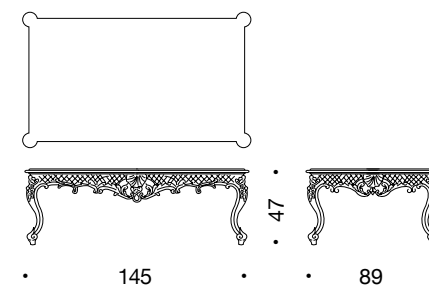

Tavolino centrale con piano marmo Onice Miele,
base intagliata con finitura a foglia Silver Gold.

Coffee table with marble top Honey Onyx, carved base
with leaf finish Silver Gold.



Art. 4014

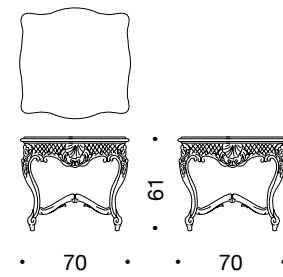

Tavolino laterale con piano marmo Onice Miele,
base intagliata con finitura a foglia Silver Gold.

Side table with marble top Honey Onyx, carved base
with leaf finish Silver Gold.



Art. 4996 /4997

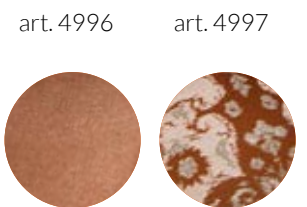
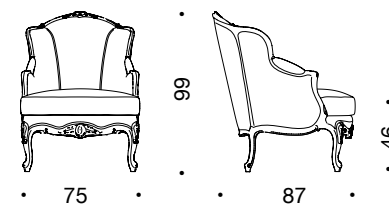

Poltrona intagliata, imbottita in tessuto, finitura laccato spelato mandarino con rilievi a foglia Silver Gold.

Non sfoderabile

Carved armchair, upholstered with fabric, finish lacquered brushed mandarin with reliefs Silver Gold leaf.

Not removable cover



Art. 4998

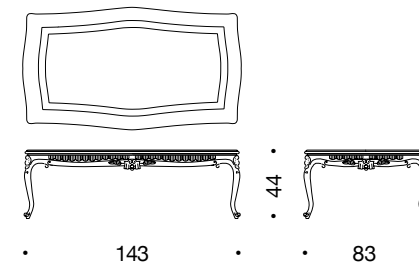

Tavolino centrale con piano intarsiato in noce canaletto, erable, ebano e acero con bordo decorato con vernice bronzata, base intagliata con finitura a foglia Silver Gold.

Coffee table with inlaid top with canaletto walnut, erable, ebony and maple with edge decorated with bronzed varnish, carved base with leaf finish Silver Gold.



Art. 5765

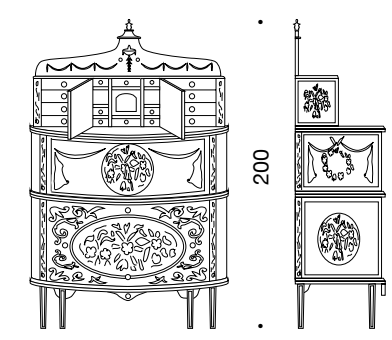

• 131 • • 58 •

Secretaire intarsiato in stile Maggiolini con citronier, radica di pomelè, acero sfumato, pero ed altre essenze, finitura naturale. Un arredo di forte valenza artistica, recuperato dagli archivi della Bellotti Ezio nella sua bellezza artigianale, fatta di molteplici e ricercati intarsi e intagli, valorizzati da una nuova finitura verniciata che mette in evidenza la naturalità del legno.

Inlaid secretaire realized with Maggiolini style with citronier, pomelè briar, gradient maple, pear and other essences, with natural finish. A highly artistic piece, recovered from the Bellotti Ezio archives, whose texture and compact composition give it a statue-like quality. The beautiful craftsmanship of multiple fine inlays and carvings have been invigorated with a new varnish finish that enhances the naturalness of the wood.



Art. 5380

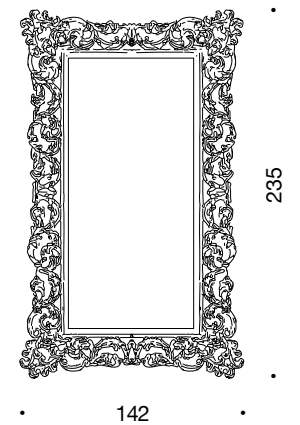

Specchiera intagliata, finitura oro a foglia anticato e dettagli bronzati.

Carved frame with mirror, antique gold leaf finish with bronzed details.



Art. 4931

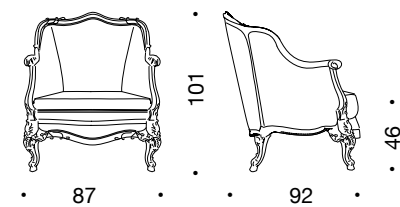

Poltrona intagliata, finitura decapè con oro a foglia anticato.

Non sfoderabile

Carved armchair, finish decapè and antique gold leaf.

Not removable cover



Art. 4935

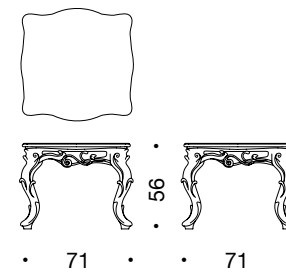

Tavolino laterale con piano in marmo Giallo Reale, finitura decapè con oro a foglia anticato.

Side table with marble top Royal Yellow, carved base, finish decapè and antique gold leaf.

Art. 1370

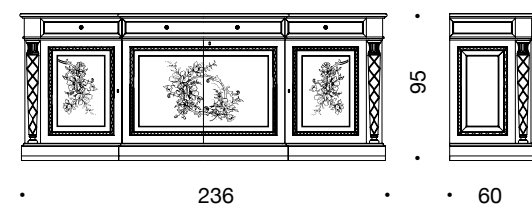

Credenza a 4 ante intarsiata in noce canaletto, erable, ebano e acero con sagome decorate con vernice bronzata, colonne decorative intagliate con finitura lucidata tonalità noce canaletto e decorate con vernice bronzata e laccato mandarino.

Sideboard with 4 doors inlaid with canaletto walnut, erable, ebony and maple with profiles decorated with bronzed varnish, carved decorative columns with polished finish canaletto walnut tonality and decorated with bronzed varnish and lacquered mandarin.



Art. 1371

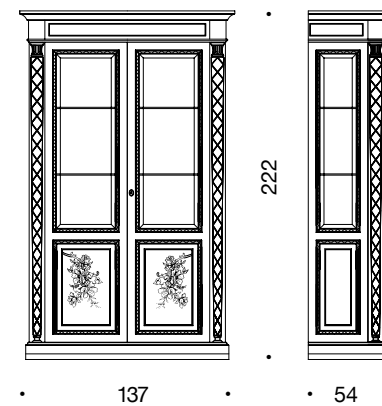

Vetrina intarsiata in noce canaletto, erable, ebano e acero con sagome decorate con vernice bronzata, colonne decorative intagliate con finitura lucidata tonalità noce canaletto e decorate con vernice bronzata e laccato mandarino.

Glass cabinet inlaid with canaletto walnut, erable, ebony and maple with profiles decorated with bronzed varnish, carved decorative columns with polished finish canaletto walnut tonality and decorated with bronzed varnish and lacquered mandarin.



Art. 1373

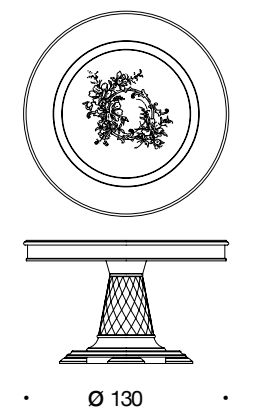

Tavolo da pranzo con piano intarsiato in noce canaletto, erable, ebano e acero con bordo decorato con vernice bronzata, base intagliata con finitura lucidata tonalità noce canaletto e decorata con vernice bronzata e laccato mandarino.

Dining table with inlaid top with canaletto walnut, erable, ebony and maple with edge decorated with bronzed varnish, carved base with polished finish canaletto walnut tonality and decorated with bronzed varnish and lacquered mandarin.



Art. 1376 / 1377



art. 1376

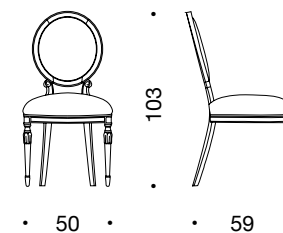

art. 1377

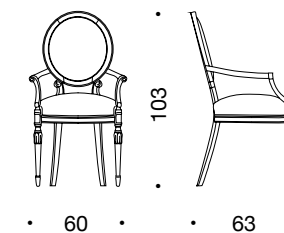

Sedia e poltroncina intagliate, imbottite in tessuto, con finitura lucidata tonalità noce canaletto e decorate con vernice bronzata.

Non sfoderabile

Carved chair and armchair, upholstered with fabric, with polished finish canaletto walnut tonality and decorated with bronzed varnish.

Not removable cover



Art. 9025 /9022



art. 9025

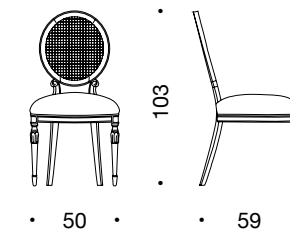

art. 9022

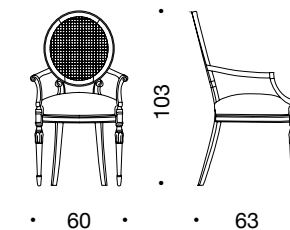

Sedia e poltroncina intagliate, imbottite in tessuto, schienale con paglia di Vienna, finitura decapè anticato.

Non sfoderabile

Carved chair and armchair, upholstered with fabric, back part realized in Vienna straw, finish antique decapè.

Not removable cover



Art. 3710

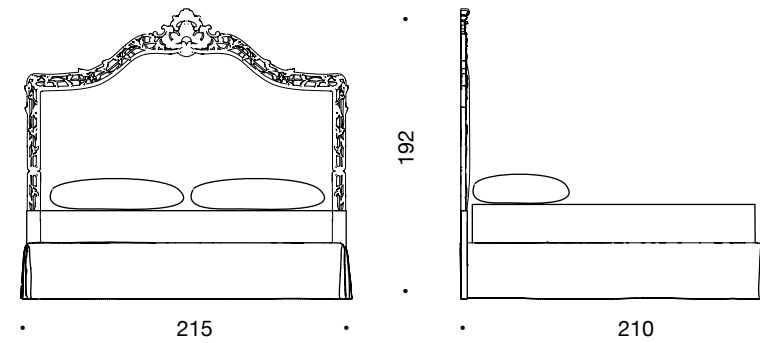

Letto con testata intagliata, pannello imbottito in tessuto, finitura a foglia Silver Gold.

Bed with carved headboard, panel upholstered with fabric, with leaf finish Silver Gold.

Art. 3712

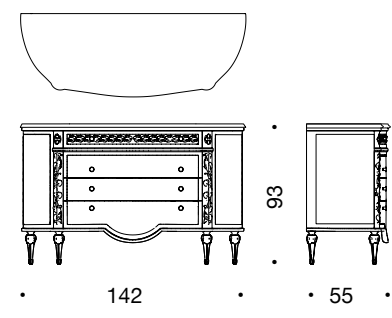

Comò con elementi intagliati, piano marmo Rosa Portogallo Estremoz, finitura laccato spelato anice con dettagli a foglia Silver Gold e decori dipinti a mano.

Chest of drawers with carved elements, marble top Rosa Portogallo Estremoz, finish lacquered brushed anise with details in Silver Gold leaf and handmade painted decorations.

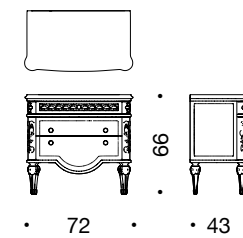

Comodino con elementi intagliati, piano marmo Rosa Portogallo Estremoz, finitura laccato spelato anice con dettagli a foglia Silver Gold e decori dipinti a mano.

Bedside table with carved elements, marble top Rosa Portogallo Estremoz, finish lacquered brushed anise with details in Silver Gold leaf and handmade painted decorations.



Art. 3715

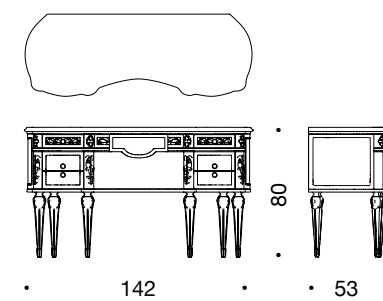

Toilette con elementi intagliati, piano marmo Rosa Portogallo Estremoz, finitura laccato spelato anice con dettagli a foglia Silver Gold e decori dipinti a mano.

Dressing table with carved elements, marble top Rosa Portogallo Estremoz, finish lacquered brushed anise with details in Silver Gold leaf and handmade painted decorations.



Art. 3716

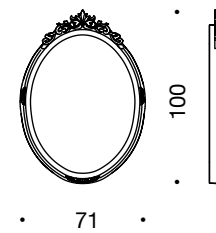

Specchiera intagliata, finitura a foglia Silver Gold.

Carved frame with mirror, finish Silver Gold leaf.



Art. 3717

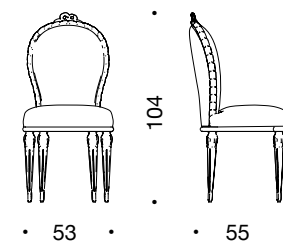

Sedia intagliata, imbottita in tessuto, finitura a foglia Silver Gold.

Carved chair, upholstered with fabric, finish Silver Gold leaf.

Non sfoderabile

Not removable cover

colophon

concept image and styling

Laura Cazzaniga

Ilaria Limonta

–

photography

Matteo Imbriani

technical photography

Ilaria Limonta

–

graphic design

Jacopo Frigerio

–

copywriter

Veronica Orsi

–

printed by

Grafica Gioia

–

special thanks to

Tom Dixon by Atalia Shop

Como

© 2022 Bellotti Ezio



Bellotti Ezio

BELLOTTI EZIO ARREDAMENTI s.r.l

Via Milano ang. Via B. Buozzi

22060 Cabiata (Co) - Italy

tel. (39) 031 766113

www.bellotti.it - bellotti@bellotti.it



Si rende noto che i colori dei legni, delle laccature, dei tessuti e delle pelli presenti nel catalogo sono suscettibili ai procedimenti di stampa e pertanto resta di riferimento il campionario dell'azienda.

Bellotti Ezio Arredamenti Srl si riserva inoltre la facoltà di modificare (in qualunque momento e senza preavviso) le caratteristiche tecniche - misure, finiture, tessuti e pelli - dei suoi prodotti, qui presentati.

We would like to point out that the colours of the woods, lacquers, fabrics and leathers present in the catalogue are susceptible to the printing procedure and therefore the company's sample book remains the reference. Bellotti Ezio Arredamenti Srl furthermore reserves the right to modify (at any time and without notice) the technical characteristics - measures, finishes, fabrics and leathers - of its products presented here.

