

Cromie collection_ *vol. II*

the voyage diaries

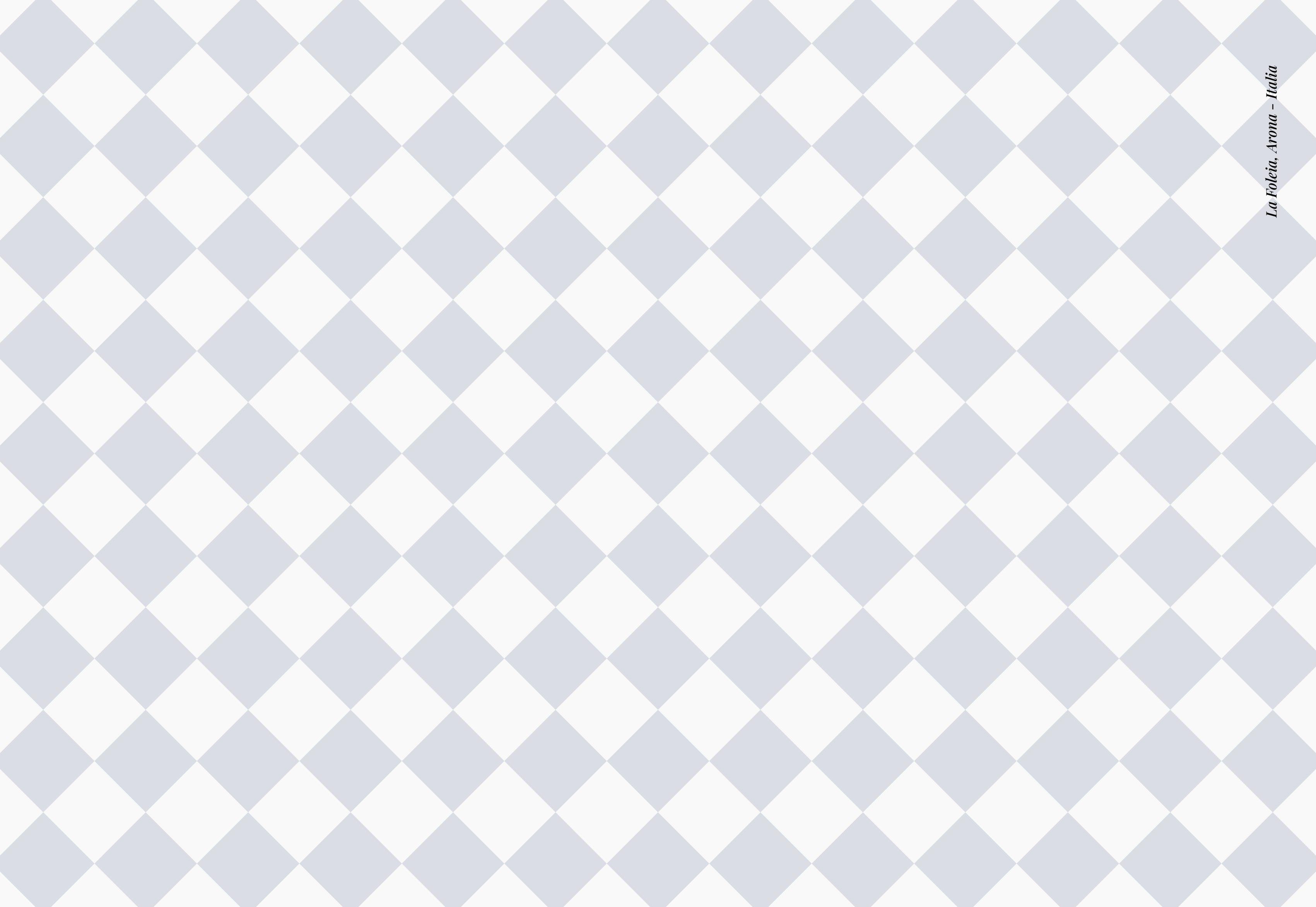

Bellotti Ezio



Cromie collection_ *vol. II*

the voyage diaries



Bellotti Ezio





Memorie, emozioni, incontri. I diari di viaggio ne sono i custodi, testimoni di profonde esperienze e affascinanti destinazioni. Con il secondo capitolo di Cromie prosegue il racconto di una riscoperta bellezza tutta italiana. Dalle sponde del Lago Maggiore verso giardini segreti.

Un luogo incantato, celato al mondo dalla natura che rigogliosa avvolge l'opera dell'uomo. Un giardino bucolico ricolmo di fiori, piante e animali, incornicia le due ville del *relais* La Foleia, i cui sguardi si incrociano al di là di uno specchio d'acqua. Come in una tela di Monet, fiori di loto e ninfee punteggiano la superficie del lago, catturando colori, luce, magia. È il mondo dei sogni, un luogo intimo e profondo, in cui abbandonarsi al riposo, alla fantasia, all'ispirazione.

☞ *“Se guardi nel modo giusto, puoi vedere che il mondo intero è un giardino”.*

Frances Hodgson Burnet

Memories, emotions, meetings. Travel journals are their guardians, witnesses of profound experiences and fascinating destinations. The story of a rediscovered typically Italian beauty continues with the second chapter of Cromie. From the shores of Lake Maggiore to secret gardens.

An enchanted place concealed from the world by the luxuriant nature that envelops the work of man. A bucolic garden overflowing with flowers, plants and animals frames the two villas of the La Foleia resort, whose views intersect beyond an expanse of water. Like in a painting by Monet, lotus flowers and water lilies dot the lake's surface and capture colours, light, magic. It is a dream world, an intimate and profound place where one can indulge in relaxation, imagination, inspiration.

Immersed in this atmosphere, in harmony with the Art-Nouveau and neoclassical style of the scene surrounding it, is the new Cromie collection. An uplifting visual narration of Bellotti Ezio's updated savoir-faire that interprets the excellence of high craftsmanship according to contemporary moods.

👉 *"If you look the right way, you can see that the whole world is a garden".*
Frances Hodgson Burnet





Immersa in questa atmosfera, in armonia con lo stile liberty e neoclassico della cornice che la circonda, la nuova collezione Cromie. Un'inebriante narrazione visiva del rinnovato savoir-faire di Bellotti Ezio che interpreta l'eccellenza dell'alto artigianato secondo mood contemporanei.



previous page

Art. 4713
Divano a 3 posti
intagliato
3 seat carved sofa
cm 220 * 102 * h 102

Art. 4711
Poltrona intagliata
Carved armchair
cm 79 * 87 * h 99

Art. 4714
Tavolino centrale
intagliato
Carved coffee table
cm 140 * 80 * h 44

this page

Art. 4715
Tavolino laterale
intagliato
Carved side table
cm 62 * 62 * h 60



Art. 5381
Specchiera con
cornice intagliata
Carved frame
with mirror
cm 122 * h 227





Art. 9311

Poltroncina intagliata
Small carved armchair
cm 62 * 63 * h 86





Art. 5382
 Specchiera con
 cornice intagliata
 Carved frame
 with mirror
 cm 150 * h 270



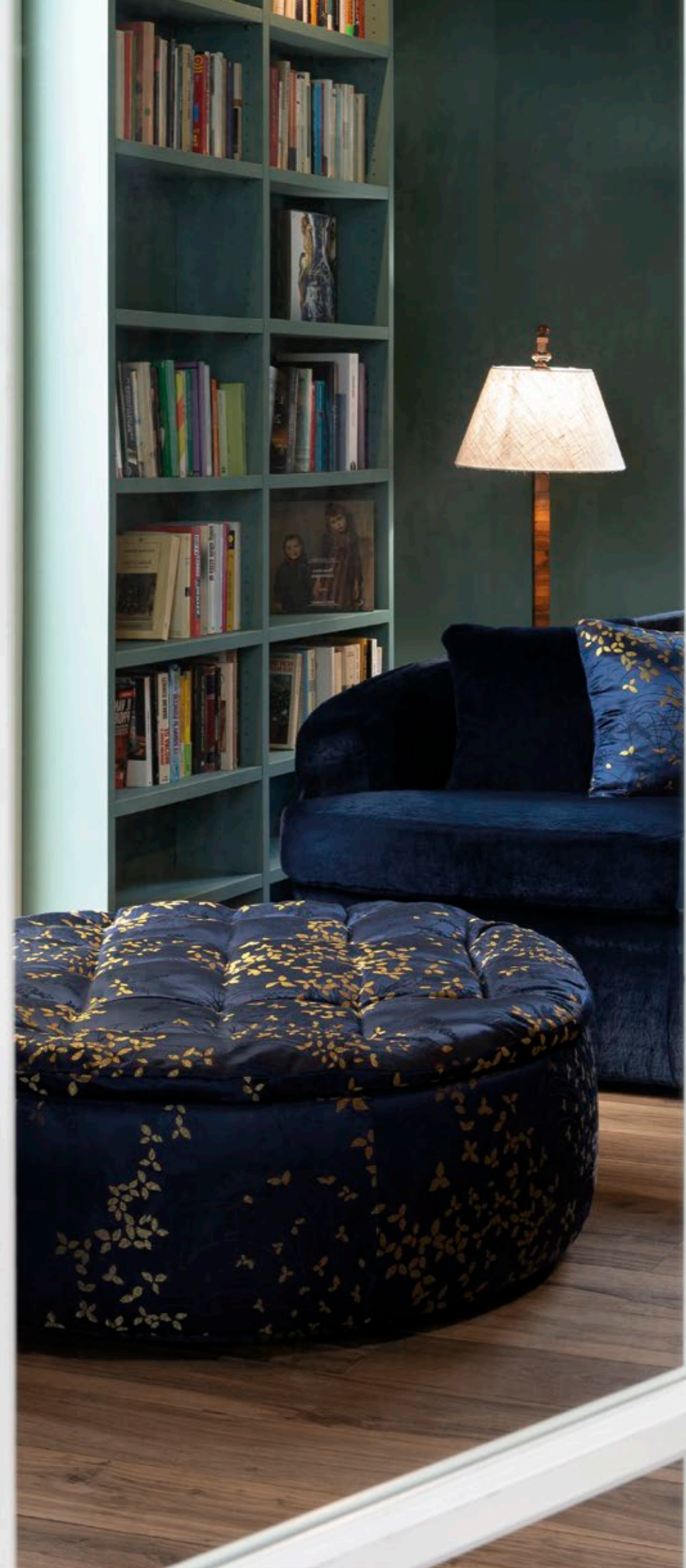

Art. 4011

Divano a 3 posti
3 seat sofa
cm 265 * 125 * h 95

Art. 4015

Pouf
Pouf
cm Ø 110 * h 41





previous page

Art. 1198

Mobile basso per TV
Low cabinet for TV
cm 250 * 53 * h 75

this page

Art. 1194

Tavolo da pranzo
Dining table
cm 270 * 125 * h 78

Art. 1196

Sedia intagliata
Carved chair
cm 51 * 53 * h 97





Art. 1197

Capotavola intagliata
Carved chair with arms
cm 61 * 57 * h 97





Art. 1194
Tavolo da pranzo
Dining table
cm 270 * 125 * h 78

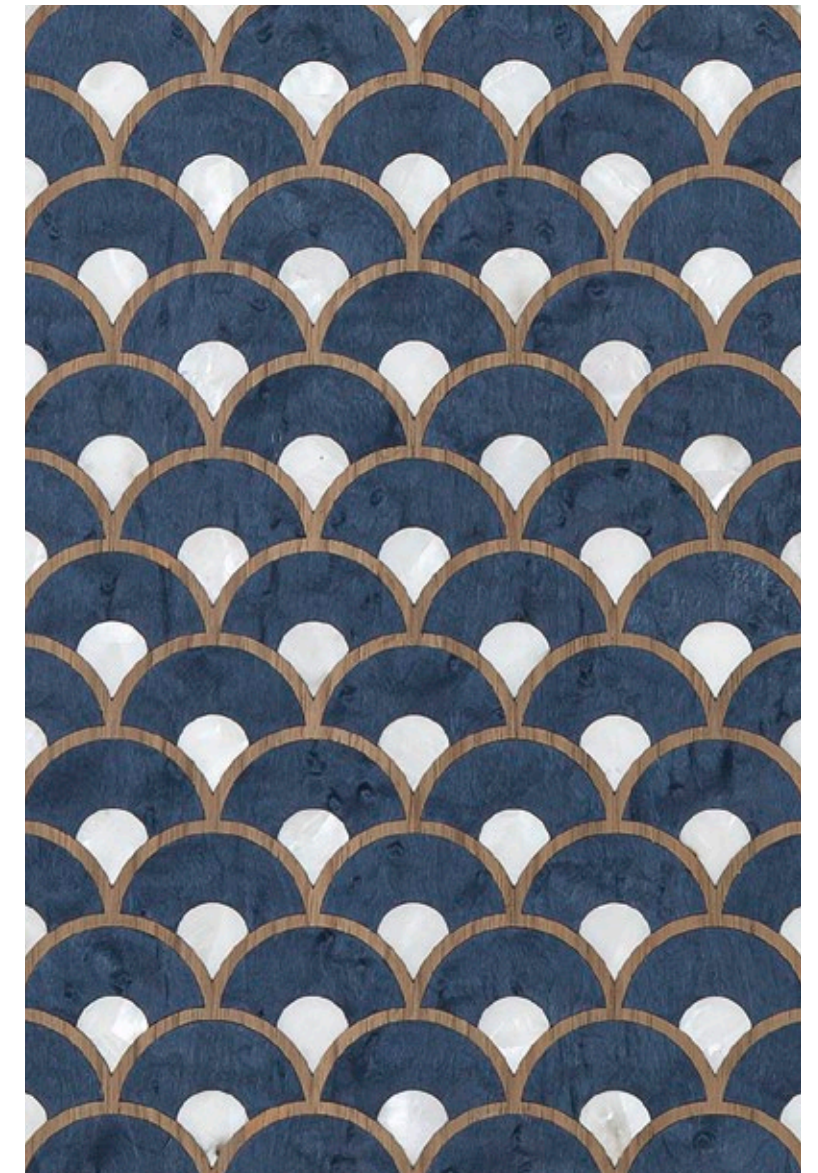



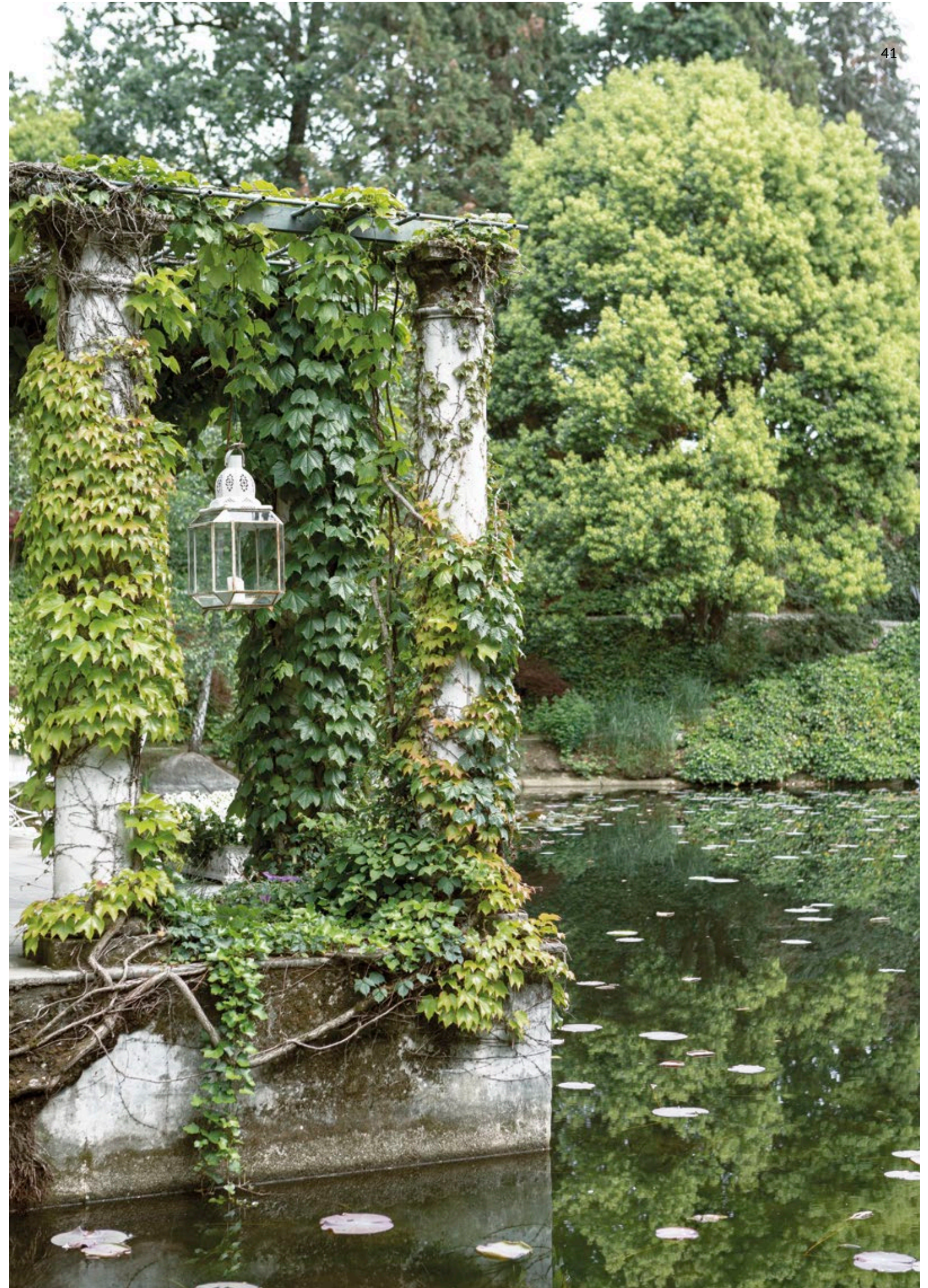

Art. 1191
Vetrina
Glass cabinet
cm 140 * 50 * h 215



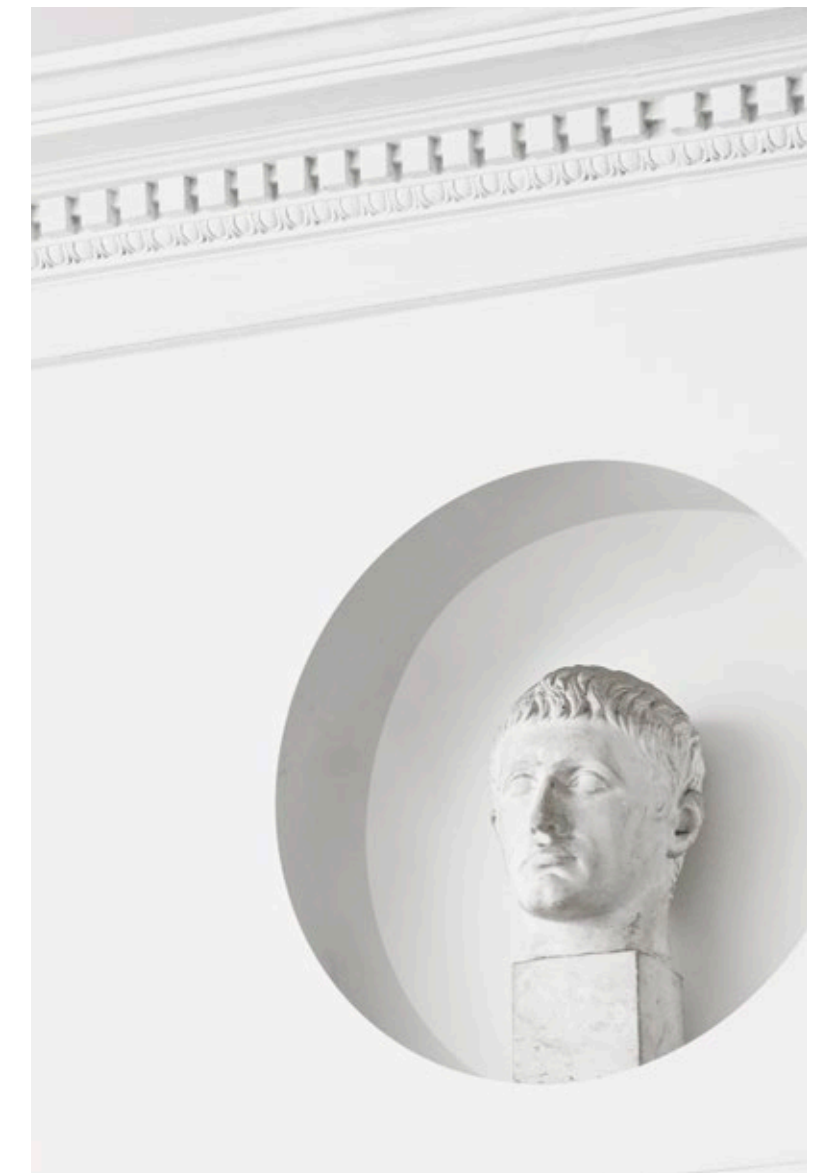

Art. 1190

Credenza a 5 ante
5 doors sideboard
cm 240 * 55 * h 90









Art. 2023-42
Tavolo rotondo
intagliato
Carved round table
cm Ø 160 * h 78

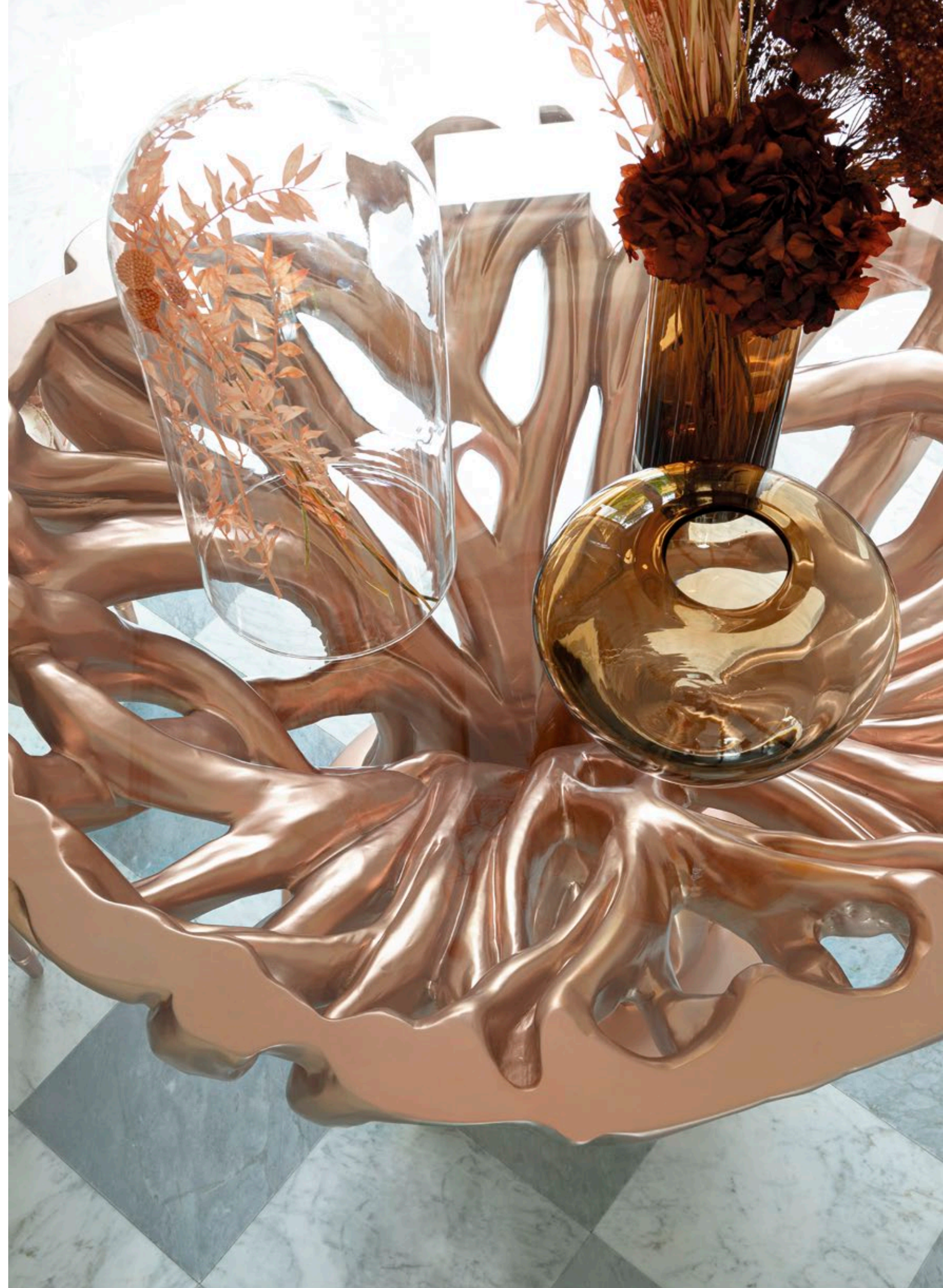

Art. 2023-42

Tavolo rotondo
intagliato
Carved round table
cm Ø 160 * h 78

Art. 9026

Capotavola intagliata
Carved chair with arms
cm 60 * 63 * h 103





Art. 3727
Panca
Bench
cm 155 * 55 * h 48

Art. 3720
Letto con testata
intagliata
*Bed with carved
headboard*
cm 247 * 234 * h 155

Art. 3722
Comodino intarsiato
Inlaid bedside table
cm 68 * 36 * h 67

Art. 3727
Panca
Bench
cm 155 * 55 * h 48



Art. 3722
Comodino intarsiato
Inlaid bedside table
cm 68 * 36 * h 67



Art. 3723

Comò intarsiato
Inlaid chest of drawers
cm 142 * 55 * h 87

Art. 3724

Specchiera con
cornice intagliata
Carved frame
with mirror
cm 79 * h 120







Art. 3725
Toilette intagliata
con specchiera
Carved dressing
table with mirror
cm 121 * 60 * h 155

Art. 3726
Pouf con schienale
Pouf with backrest
cm Ø 50 * h 68



Art. 3723
Comò intarsiato
Inlaid chest of drawers
cm 142 * 55 * h 87





The heartening nature of Lotus green and the dream-like spirit of Anemone blue pervade the new collection items, warming hearts and arousing the senses. A soft and elegant palette expressly evocative of a natural dimension in continuous relationship with the landscape.

Il carattere rasserenante del verde Loto e lo spirito onirico del blu Anemone pervadono le novità della collezione, scaldando gli animi e solleticando i sensi. Una palette delicata ed elegante, espressamente evocativa di una dimensione naturale, in relazione continua con il paesaggio.

- 1** pelliccia ecologica verde
green faux fur
- 2** fiori di ciliegio jacquard
cherry blossoms jacquard
- 3** laccato spelato tempera
francese verde loto
*finish lacquered and brushed
green lotus french tempera*
- 4** carta da parati verde
green wallpaper
- 5** marmo Verde Lapponia
marble Green Lapponia
- 6** maniglia decorativa
decorative handle
- 7** ciniglia a coste
corduroy chenille
- 8** acero frise con intarsi in
madreperla e filetto a
rombi in essenza Tay
*maple frise veneer with
inlays in mother-of-pearl and
romb prifle in Tay veneer*
- 9** lampasso di ciniglia
chenille lampas
- 10** velluto stampato
printed velvet
- 11** lino ricamato
embroidered linen
- 12** velluto jacquard a scacchi
checkered jacquard velvet
- 13** passamanerie
trimmings

I colori della verdeggiante vegetazione rivivono nell'interior. Si rintracciano nel moodboard Loto, una palette autentica, riflessiva, soave. Dipinge tessuti tinta unita, ricami floreali, marmi e intarsi. Applicata nella finitura delle essenze, questa tonalità permette di introdurre la laccatura alla francese, a base d'acqua, dunque affine a un approccio sostenibile ed ecologico. Il verde Loto esprime la serenità della natura, evoca un ideale "giardino d'inverno" dove rigenerarsi e ritrovare sé stessi.

The colours of the verdant vegetation are revived in the interior. They are found in the Lotus moodboard, an authentic, thoughtful, melodious palette. It paints plain colour fabrics, floral embroidery, marbles and inlays. Applied in the finish of the woods, with this shade the water-based French polishing can be introduced, so it is similar to a sustainable and eco-friendly approach. Lotus green expresses the serenity of nature, evokes an ideal "winter garden" where one can be rejuvenated and find oneself.



Loto

- 1** laccato sakura con effetto metallizzato opaco
finish lacquered sakura with matt metal effect
- 2** maniglia decorativa
decorative handle
- 3** finitura a foglia Silver Gold
leaf finish Silver Gold
- 4** laccato grigio opaco con intagli decorati Silver Gold
finish lacquered grey matt with Silver Gold decorated carvings
- 5** damasco jacquard
damask jacquard
- 6** jacquard di seta blu
silk jacquard blue
- 7** carta da parati blu
blue wallpaper
- 8** jacquard di seta avorio
silk jacquard ivory
- 9** paglia di Vienna laccata sakura con effetto metallizzato opaco
Vienna straw lacquered sakura with matt metal effect
- 10** pelliccia ecologica blu
blue faux fur
- 11** laccato spelato tempera francese blu anemone
finish lacquered and brushed blue anemone french tempera
- 12** passamanerie
trimmings
- 13** essenza noce canaletto tinto grigio e filetti decorativi in erable tinto blu e noce
canaletto walnut veneer tinged grey and decorative profiles with erable tinged blue and walnut
- 14** lino jacquard
linen jacquard
- 15** intarsio in madreperla, erable tinto blu e filetto in noce canaletto
inlay with mother-of-pearl, erable tinged blue with profile in canaletto walnut

Un'intensità raffinata definisce il moodboard Anemone, un tripudio di sfumature decise addolcite dalla tinta rosa Sakura, i cui accenti delicati creano una melodia d'insieme con il blu dominante. Nei tessuti, nella morbida pelliccia, nei laccati e negli intarsi abbinati alla madreperla, a creare un motivo a squame di ispirazione giapponese, la palette rimanda alle cromie dei cieli e dei mari: allo stesso modo gli arredi generano un orizzonte infinito, una prospettiva senza confini. Un omaggio alla classicità, che è oltre il tempo e oltre lo spazio.

A refined intensity defines the Anemone moodboard, a jubilation of sharp shades softened by the pink hue Sakura, whose delicate accents create an overall melody with blue dominating. The palette reflects the colours of the skies and seas in the fabrics, in the soft fur, in the French-polished pieces and in the inlays combined with mother-of-pearl, creating a Japanese-inspired scale pattern. In the same way, the furnishings generate an infinite horizon, a boundless view. Homage is paid to classicism, which is beyond time and beyond space.



Anemone

Catalogo dei prodotti_ *Product catalogue*

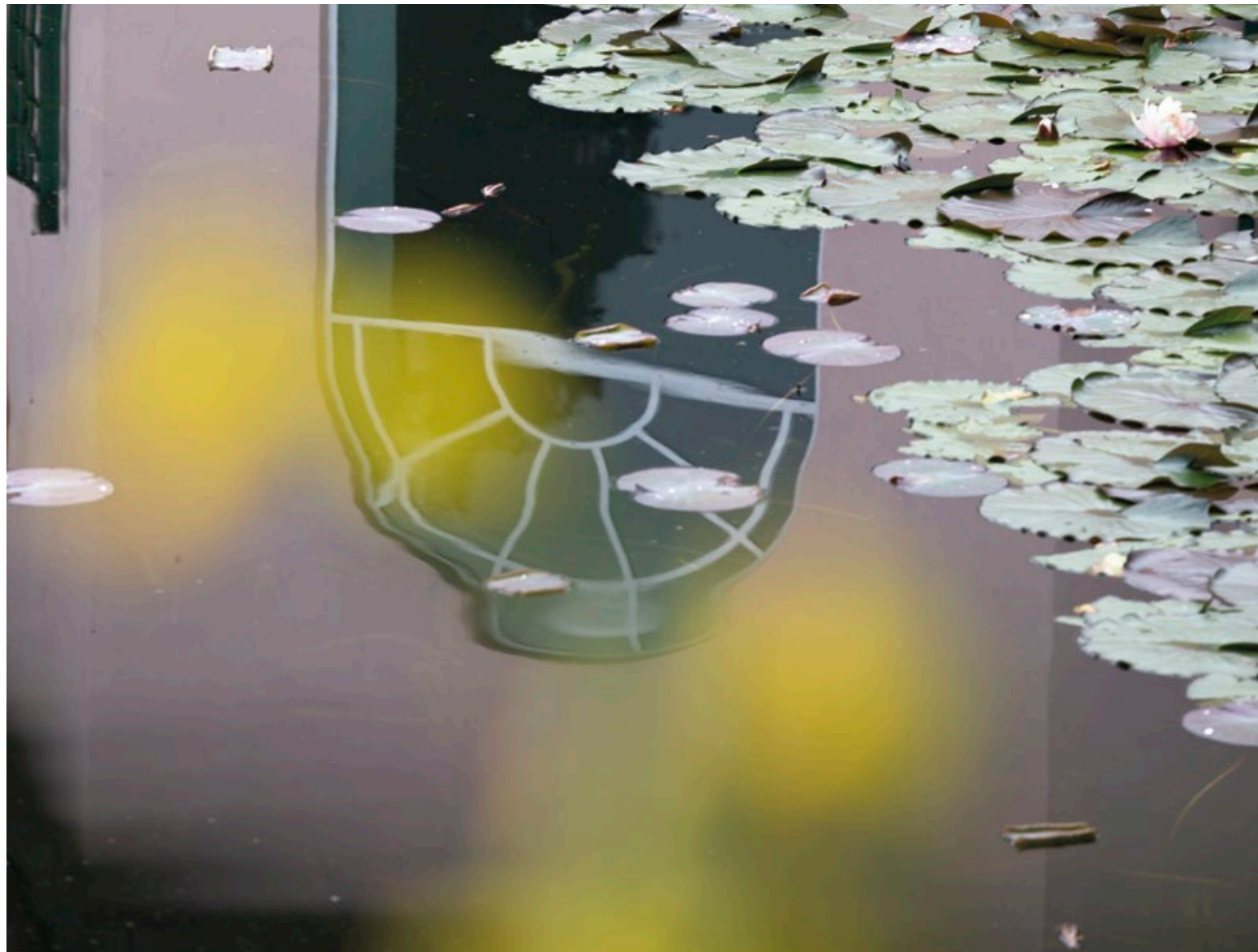



Art. 4713

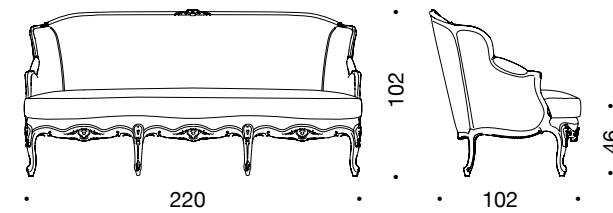

Divano a 3 posti intagliato in legno, imbottito in tessuto, finitura laccato spelato tempera francese colore verde loto con rilievi Silver Gold.

Non sfoderabile

3 seat sofa in carved wood, upholstered with fabric, finished in lacquered and brushed green lotus french tempera with Silver Gold details.

Not removable cover



Art. 4711

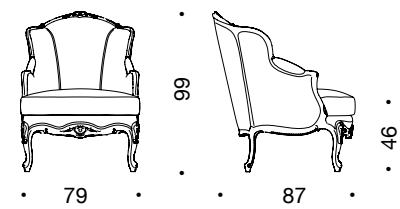

Poltrona intagliata, imbottita in tessuto,
finitura a foglia Silver Gold.

Non sfoderabile

Armchair in carved wood, upholstered with fabric,
Silver Gold leaf finish.

Not removable cover



Art. 4714

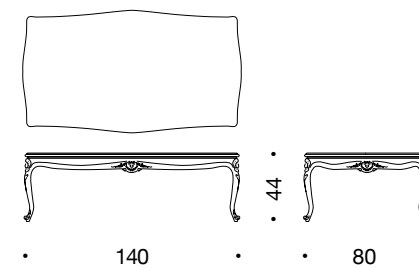

Tavolino centrale con piano marmo Verde Lapponia, base intagliata in legno con finitura laccato spelato tempera francese colore verde loto con rilievi Silver Gold.

Coffee table with marble top Green Lapponia, carved wood base finished in lacquered and brushed green lotus french tempera with Silver Gold details.



Art. 4715

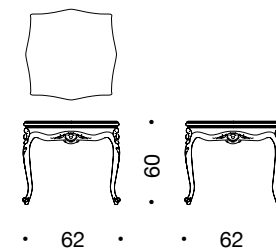

Tavolino laterale con piano marmo Verde Lapponia, base intagliata in legno con finitura laccato spelato tempera francese colore verde loto con rilievi Silver Gold.

Side table with marble top Green Lapponia, carved wood base finished in lacquered and brushed green lotus french tempera with Silver Gold details.



Art. 5381

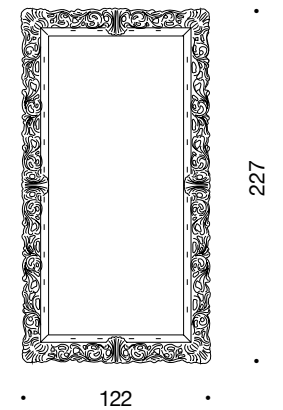

Specchiera con cornice intagliata in legno, finitura laccato spelato tempera francese colore verde loto, specchio fumè.

Frame in carved wood with mirror, finished in lacquered and brushed green lotus french tempera, fumè mirror.



Art. 9311

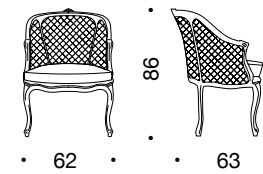

Poltroncina intagliata in legno, schienale in paglia di Vienna, seduta imbottita in tessuto, finitura laccato spelato tempera francese colore verde loto.

Non sfoderabile

Small armchair in carved wood, backrest in Vienna straw, seat upholstered with fabric, finished in lacquered and brushed green lotus french tempera.

Not removable cover



Art. 5382

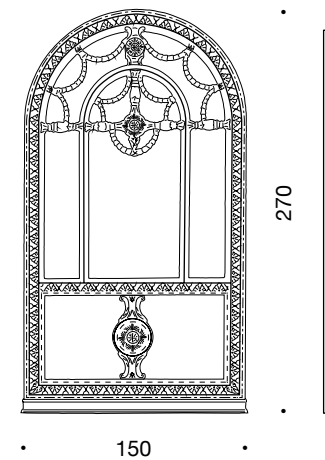

Specchiera con cornice intagliata in legno, finitura laccato spelato tempera francese colore blu anemone.

Frame in carved wood with mirror, finished in lacquered and brushed blue anemone french tempera.



Art. 4011

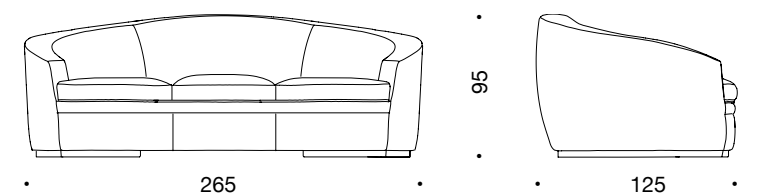

Divano 3 posti in poliuretano espanso indeformabile a densità differenziate e fibra poliestere con struttura interna in legno. Piedi rivestiti in tessuto. Disponibile con rivestimento in tessuto nei colori del campionario. Cuscini decorativi in misto piuma.

Non sfoderabile

3 seat sofa in non-deformable foam polyurethane in different density and polyester fibre with wooden inside structure. Feet covered in fabric. Available covered by fabric as per samples. Decorative cushions with mix feather.

Not removable cover



Art. 4015

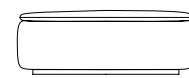
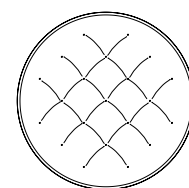

• Ø 110 •

• 41 •

Pouf in poliuretano espanso indeformabile a densità differenziate e fibra poliestere con struttura interna in legno. Disponibile con rivestimento in tessuto nei colori del campionario.

Non sfoderabile

Pouf in non-deformable foam polyurethane in different density and polyester fibre with wooden inside structure. Available covered by fabric as per samples.

Not removable cover

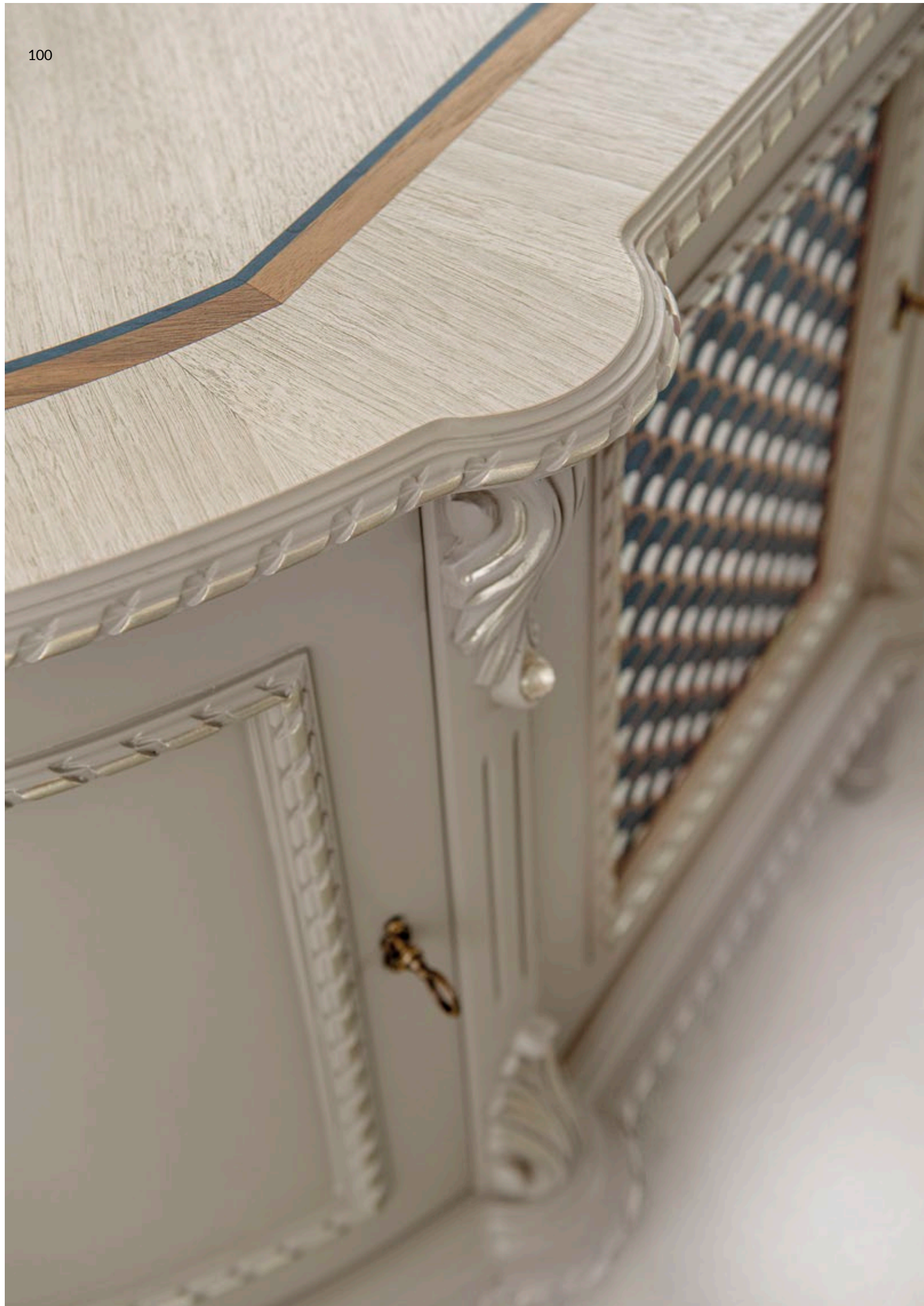

Art. 1198

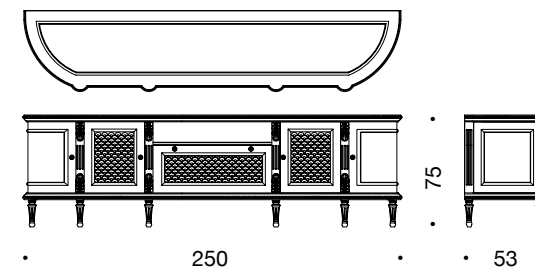

Mobile basso per TV, struttura e parti in legno massello con 2 ante laterali con finitura laccato grigio opaco, 3 ante centrali finemente intarsiate in madreperla, erable tinto blu e filetto in noce canaletto, con vano a giorno, top in legno impiallacciato in noce canaletto tinto grigio e filetti decorativi in erable tinto blu e noce, con intagli decorati.

Low cabinet for TV, structure and parts in solid wood with 2 lateral doors with matt grey lacquered finish, 3 central doors finely inlaid with mother-of-pearl, erable tinged blue with profile in canaletto walnut, with open compartment, wooden top veneered in canaletto walnut tinged grey and decorative profiles with erable tinged blue and walnut, with decorated carvings.



Art. 1194

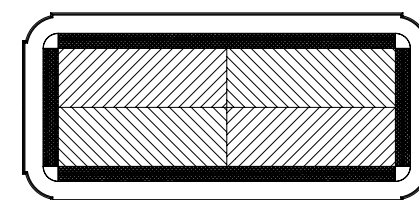

270

78

125

Tavolo da pranzo con piano in noce canaletto tinto grigio e fascia decorativa finemente intarsiata in madreperla, erable tinto blu e filetto in noce canaletto, gambe in massello di legno intagliate laccate grigio opaco con intagli decorati.

Dining table with top in canaletto walnut tinged grey and decorative band finely inlaid with mother-of-pearl, erable tinged blue with profile in canaletto walnut, legs in carved solid wood lacquered grey matt with decorated carvings.

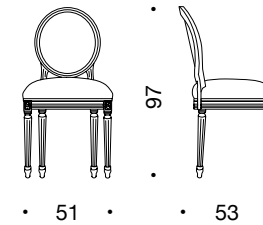

Sedia intagliata in legno, imbottita in tessuto, finitura a foglia Silver Gold.

Chair in carved wood, upholstered with fabric, Silver Gold leaf finish.

Non sfoderabile

Not removable cover



Art. 1197

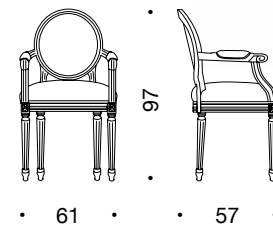

Capotavola intagliata in legno, imbottita in tessuto,
finitura a foglia Silver Gold.

Non sfoderabile

Chair with arms in carved wood, upholstered with fabric,
Silver Gold leaf finish.

Not removable cover



Art. 1190

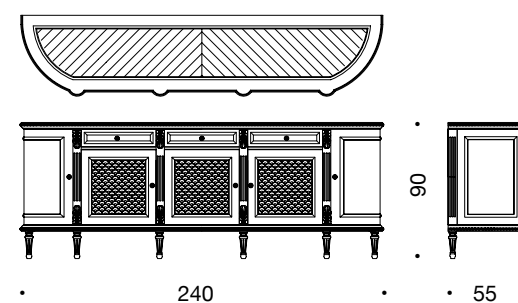

Mobile a 5 ante, struttura e parti in legno massello con finitura laccato grigio opaco, 3 cassetti e 2 ante laterali con finitura laccato grigio opaco, 3 ante centrali finemente intarsiate in madreperla, erable tinto blu e filetto in noce canaletto, top in legno impiallacciato in noce canaletto tinto grigio e filetti decorativi in erable tinto blu e noce, con intagli decorati.

5 doors sideboard, structure and parts in solid wood with matt grey lacquered finish, 3 drawers and 2 lateral doors with matt grey lacquered finish, 3 central doors finely inlaid with mother-of-pearl, erable tinged blue with profile in canaletto walnut, wooden top veneered in canaletto walnut tinged grey and decorative profiles with erable tinged blue and walnut, with decorated carvings.



Art. 1191

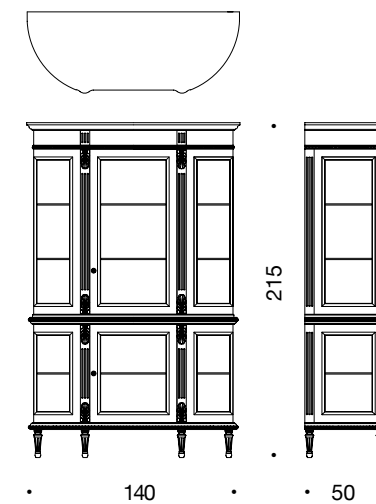

Vetrina, con schienale in tessuto, finitura della struttura laccato blu opaco, ante con vetro e fascia in erable tinto blu.

Glass cabinet, with back part with fabric, structure finish lacquered matt blue, doors with glass and band in erable tinged blue.



Art. 2023-42

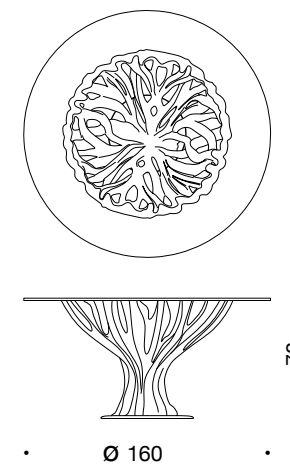

Tavolo rotondo intagliato in massello di tiglio, finitura laccata colore sakura con effetto metallizzato opaco, piano in cristallo trasparente.

Carved round table in solid lime wood, finish lacquered sakura colour with matt metal effect, transparent crystal top.



Art. 9026 /9027



art. 9027

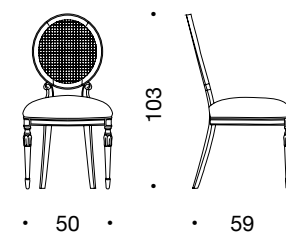

art. 9026

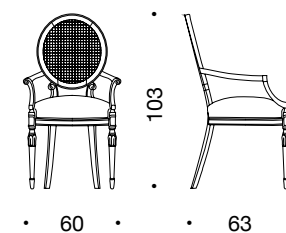

Capotavola intagliata in legno, schienale con paglia di Vienna, imbottita in tessuto, finitura laccata colore sakura con effetto metallizzato opaco.

Non sfoderabile

Chair with arms in carved wood, backrest in Vienna straw, upholstered with fabric, finish lacquered sakura colour with matt metal effect.

Not removable cover



Art. 3720

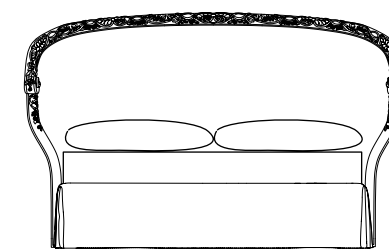

247

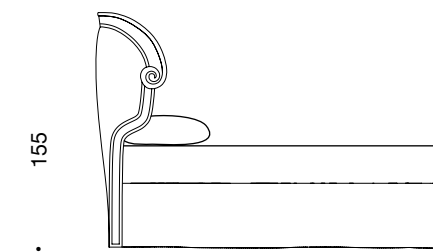

155

234

Letto con testata intagliata in legno, pannello imbottito in tessuto, finitura a foglia Silver Gold.

Bed with headboard in carved wood, panel upholstered with fabric, Silver Gold leaf finish.



Art. 3727

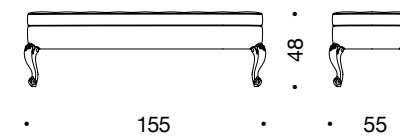

Panca con gambe intagliate, imbottita in tessuto, finitura a foglia Silver Gold.

Bench with legs in carved wood, upholstered with fabric, Silver Gold leaf finish.



Art. 3722

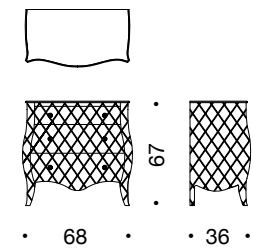

Comodino impiallacciato in acero frise con intarsi in madreperla e filetto a rombi in essenza Tay, piano in cristallo verniciato verde loto, maniglie in ottone.

Bedside table veneered in maple frise with inlays in mother-of-pearl and romb prifle in Tay veneer, top in varnished glass green lotus, with decorative brass handles.

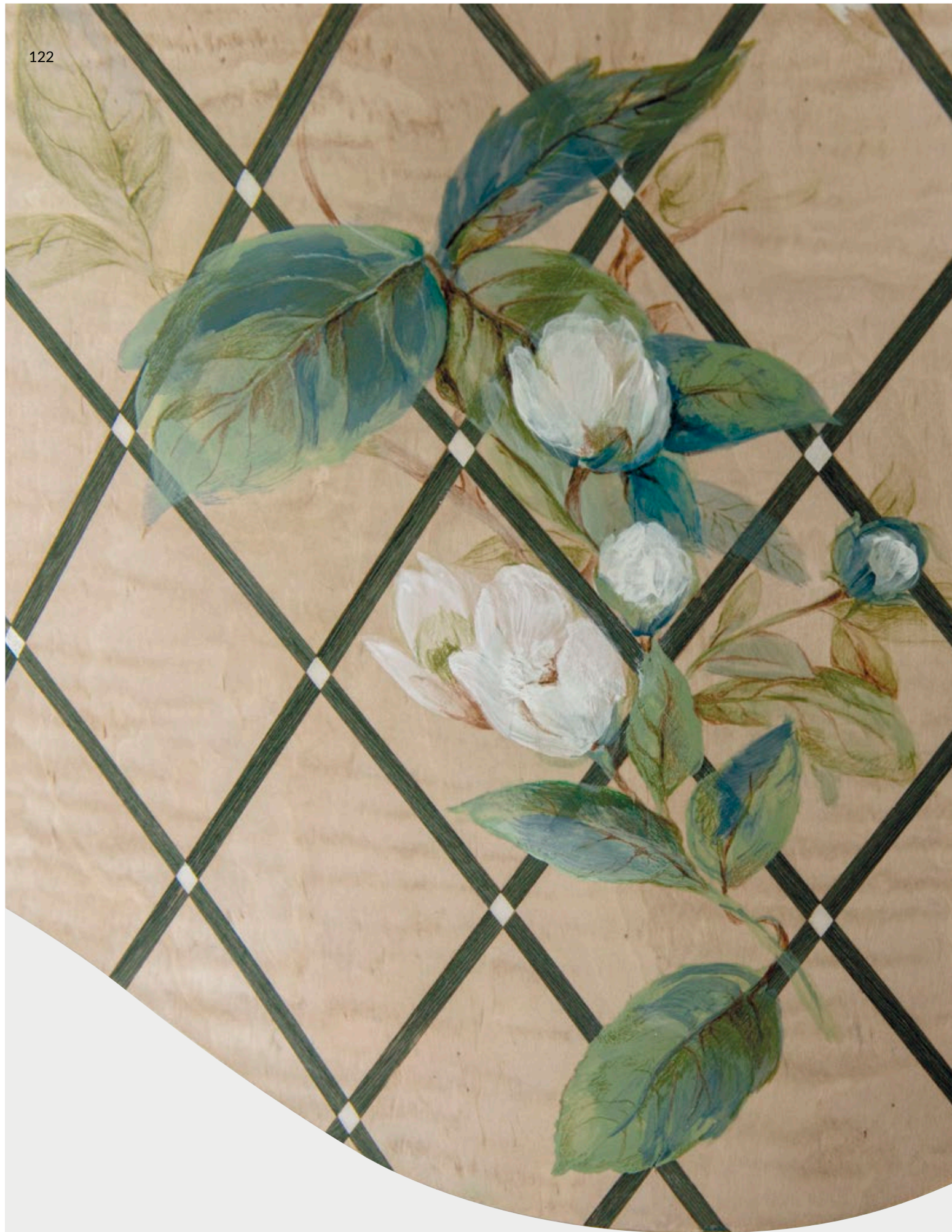

Art. 3723

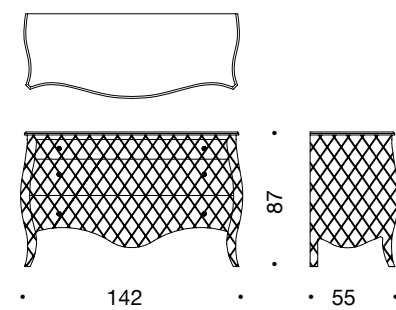

Comò impiallacciato in acero frise con intarsi in madreperla e filetto a rombi in essenza Tay, con decorazione floreale dipinta a mano, piano in cristallo verniciato verde loto, maniglie in ottone.

Chest of drawers veneered in maple frise with inlays in mother-of-pearl and romb profile in Tay veneer, with hand-painted floral decoration, top in varnished glass green lotus, with decorative brass handles.



Art. 3724

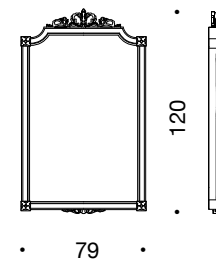

Specchiera con cornice intagliata in legno, finitura a foglia Silver Gold.

Frame in carved wood with mirror, Silver Gold leaf finish.



Art. 3725

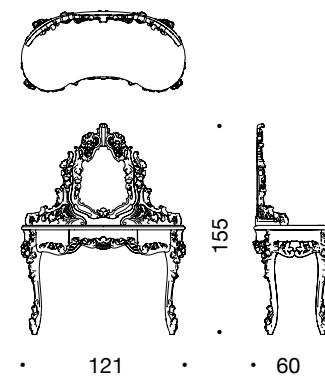

Toilette con specchiera intagliata in legno, finitura a foglia Silver Gold.

Dressing table with mirror in carved wood, Silver Gold leaf finish.



Art. 3726

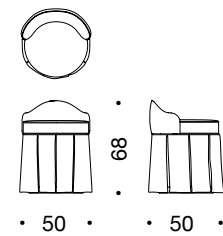

Pouf con schienale imbottito in tessuto.

Non sfoderabile

Pouf with backrest upholstered with fabric.

Not removable cover



Si rende noto che i colori dei legni, delle laccature, dei tessuti e delle pelli presenti nel catalogo sono suscettibili ai procedimenti di stampa e pertanto resta di riferimento il campionario dell'azienda. Bellotti Ezio Arredamenti Srl si riserva inoltre la facoltà di modificare (in qualunque momento e senza preavviso) le caratteristiche tecniche - misure, finiture, tessuti e pelli - dei suoi prodotti, qui presentati.

We would like to point out that the colours of the woods, lacquers, fabrics and leathers present in the catalogue are susceptible to the printing procedure and therefore the company's sample book remains the reference. Bellotti Ezio Arredamenti Srl furthermore reserves the right to modify (at any time and without notice) the technical characteristics - measures, finishes, fabrics and leathers - of its products presented here.

colophon

concept image and styling

Laura Cazzaniga

Ilaria Limonta

–

photography

Paolo Golumelli

technical photography

Ilaria Limonta

–

graphic design

Jacopo Frigerio

–

copywriter

Veronica Orsi

–

prepress

Compos Center

–

printed by

Grafica Gioia

© 2023 Bellotti Ezio



Bellotti Ezio

BELLOTTI EZIO ARREDAMENTI s.r.l

Via Milano ang. Via B. Buozzi

22060 Cabiato (Co) - Italy

tel. (39) 031 766113

www.bellotti.it - bellotti@bellotti.it



