



by Bellotti Ezio

3

CONTEMPORARY FEEL



by Bellotti Ezio

3

CONTEMPORARY FEEL



by Bellotti Ezio

GEA
collection

HALL

06

LIVING

14 - 84 - 136

DINING

30 - 60

BEDROOM

42 - 114

WALK-IN CLOSET

52

**TECHNICAL
INFORMATION**

246



by Bellotti Ezio

DELFI
collection

HALL

144

DINING

154

LIVING

178

BEDROOM

218

LIGHTING

236

**TECHNICAL
INFORMATION**

266

A top-down view of a circular wooden structure, possibly a table or a decorative piece. The structure is composed of concentric rings of wood. The outermost ring is a light-colored wood, while the inner rings are a darker, greyish wood. In the center, there is a circular opening with a complex, lattice-like pattern. The overall design is organic and inspired by natural forms.

GEA
collection

La collezione di arredi GEA disegnata dall'architetto Giovanni Luca Ferreri è un omaggio alle forme e ai colori della Terra.

Ogni singolo pezzo di questa collezione nasce e si ispira alle geometrie e alle forme della natura. Dettagli e finiture in tutti gli arredi e i complementi della nuova collezione esprimono questa appartenenza. Una collezione che si ispira alla tradizione nordica, rivista attraverso la sapienza dell'alta ebanisteria italiana. Ebano bianco, Ziricote, Noce Canaletto e frassino sono le essenze che proponiamo in diverse declinazioni combinandole a metalli e pelli che ne esaltano le qualità.

The GEA furniture collection, designed by the architect Giovanni Luca Ferreri, is a tribute to the shapes and colours of the Earth.

Each and every single piece of this collection is born and inspired by the geometries and shapes of nature. Details and finishes in all the furnishings and accessories of this new collection express these roots – this is a collection inspired by the Nordic tradition, revisited through the skills and expertise of high Italian artisan craftsmanship. White ebony, Ziricote, Canaletto walnut and ash are the wood types offered in numerous versions, combining them with metal and leather in order to wonderfully enhance their qualities.

Hall





REA 2019-21
Poltrona - *Armchair*
cm. 92 * 72 * h. 92

PATAGONIA 2019-26
Tavolino piano marmo Calacatta oro
Coffee table marble top Calacatta gold
cm. 100 * 100 * h. 34

PEGASO 2019-40
Tavolo scultura - *Sculpture table*
cm. Ø 142 * h. 82

GEA
collection

“

La collezione GEA accosta diversi materiali combinandoli per contrasto o assonanza, segnando il carattere del singolo arredo o complemento che appartiene a questa collezione.

Il legno - nelle sue diverse essenze - è il tema dominante.

The GEA collection blends perfectly together different materials, combining them by contrast or assonance, defining the character and personality of the single piece of furniture, as well as occasional furnishings, that are part to this collection.

Wood - in its various types - is the dominant theme.

”

FEBE 2019-35
Consolle - Console
cm. 140 * 40 * h. 87

FEBE 2019-37
Specchiera - Mirror
cm. 96 * h. 210



GEA
collection



“

Sono forme eleganti che celebrano la vita
in tutte le sue espressioni.

*These elegant forms celebrate life
in all its expressions.*

”



FEBE 2019-35
Consolle - Console
cm. 140 * 40 * h. 87

FEBE 2019-36
Specchiera - Mirror
cm. 96 * h. 210

Living



ARES 2019-02 / 2019-04
Divano 2 posti con penisola
2 seats sofa with chaise longue
cm. 325 * 132 * h. 75



GEA
collection



PATAGONIA 2019-25
Tavolino piano marmo Silver wave
Coffee table marble top Silver wave
cm. 140 * 60 * h. 26

PATAGONIA 2019-11
Tavolino piano marmo Patagonia
Coffee table marble top Patagonia
cm. 130 * 91 * h. 42

PATAGONIA 2019-26
Tavolino piano marmo Calacatta oro
Coffee table marble top Calacatta gold
cm. 100 * 100 * h. 34

PATAGONIA 2019-12
Tavolino piano marmo Patagonia
Side table marble top Patagonia
cm. 70 * 70 * h. 71



FIDIA 2019-16
Piedistallo - Pedestal table
cm. 38 * 38 * h. 122

ARES 2019-01
Divano 3 posti - 3 seats sofa
cm. 281 * 132 * h. 75

GEA
collection



ARES 2019-02 / 2019-04
Divano 2 posti con penisola
2 seats sofa with chaise longue
cm. 325 * 132 * h. 75

ARES 2019-01
Divano 3 posti - 3 seats sofa
cm. 281 * 132 * h. 75

PATAGONIA 2019-25
Tavolino piano marmo Silver wave
Coffee table marble top Silver wave
cm. 140 * 60 * h. 26

PATAGONIA 2019-26
Tavolino piano marmo Calacatta oro
Coffee table marble top Calacatta gold
cm. 100 * 100 * h. 34

PATAGONIA 2019-11
Tavolino piano marmo Patagonia
Coffee table marble top Patagonia
cm. 130 * 91 * h. 42

PATAGONIA 2019-12
Tavolino piano marmo Patagonia
Side table marble top Patagonia
cm. 70 * 70 * h. 71

FIDIA 2019-16
Pedistallo
Pedestal table
cm. 38 * 38 * h. 122

GEA
collection



by Bellotti Ezio



REA 2019-20
Poltrona in Noce Canaletto
Armchair in Canaletto Walnut
cm. 92 * 72 * h. 92

DEDALO 2019-31
Tavolino in Noce Canaletto
Small table in Canaletto Walnut
cm. 61 * 61 * h. 63

PATAGONIA 2019-25
Tavolino piano marmo Silver Wave
Coffee table marble top Silver Wave
cm. 140 * 60 * h. 26

PATAGONIA 2019-26
Tavolino piano marmo Calacatta Oro
Coffee table marble top Calacatta Gold
cm. 100 * 100 * h. 34

ZEUS 2018-42
Mobile bar in Ziricote
Bar cabinet in Ziricote wood
cm. 110 * 55 * h. 180

GEA
collection



“

La struttura dalle linee nordiche è in legno massello di Noce Canaletto o Frassino tinto nero a poro aperto. La seduta imbottita è in tessuto con schienale rivestito in cuoio caratterizzata dalle cuciture a vista. Disponibile in diverse combinazioni cromatiche.

The frame, defined by Nordic lines, is made of solid Canaletto Walnut or black stained open pore ash. The padded seat is in fabric with a backrest upholstered in leather, wonderfully defined by visible stitching. Available in different colour combinations.

”



REA 2019-20
Poltrona in Noce Canaletto
Armchair in Canaletto Walnut
cm. 92 * 72 * h. 92

GEA
collection



ZEUS 2018-42
Mobile bar in Ziricote
Bar cabinet in Ziricote wood
cm. 110 * 55 * h. 180



PANGEA 2018-63
Mobile TV - TV cabinet
cm. 180 * 50 * h. 60

Dining



GEA
collection



ATENA 2018-40
Mobile in Ziricote
Sideboard in Ziricote wood
cm. 175 * 50 * h. 85





GEA
collection



FEBE 2018-65
Sedia in Frassino
Chair in Ash wood
cm. 49 * 54 * h. 92

“

Un design in cui il legno diviene elemento duttile e plasmabile.
Un invito a sentire le forme attraverso tutti i sensi.

*This is a design in which wood is a versatile element –
an invitation to truly feel
these forms through all the senses.*

”

GEA
collection



DOLOMIA 2018-50
Elementi contenitori con boiserie
Wall cabinet system
cm. 300 * 60 * h. 306

“

Per i contenitori abbiamo selezionato i legni dalle texture più singolari.

For the storage units, we have chosen wood types with the most unique textures.

”



PROMETEO 2018-55
Tavolo - Table
cm. 330 * 120 * h. 72

DEMETRA 2018-66
Capotavola in Frassino
Chair with arms in Ash wood
cm. 60 * 64 * h. 85

GEA
collection



DEMETRA 2018-58
Capotavola in Noce Canaletto
Chair with arms in Canaletto Walnut
cm. 60 * 64 * h. 85

Bedroom





FIDIA 2019-17
Piedistallo - Pedestal table
cm. 38 * 38 * h. 122



CRONO 2018-80
Letto in Frassino
Bed in Ash wood
cm. 236 * 240 * h. 143

LAPETO 2018-83
Comodino in Ebano bianco
Night table in white Ebony
cm. 65 * 46 * h. 57

LAPETO 2018-81
Comò in Ebano bianco
Chest of drawers in white Ebony
cm. 120 * 56 * h. 88

ATENA 2018-44
Specchiera in ottone
Mirror in brass
cm. 153 * h. 100

GEA
collection



SELENE 2018-76
Dormeuse - *Dormeuse*
cm. 182 * 97 * h. 74

DEDALO 2019-32
Tavolino in Frassino
Small table in Ash wood
cm. 61 * 61 * h. 63

AFRODITE 2018-84
Consolle trucco - *Vanity*
cm. 125 * 46 * h. 76

LAPETO 2018-72
Specchiera - *Mirror*
cm. 77 * h. 122

AFRODITE 2018-75
Specchiera - *Mirror*
cm. 30 * 20 * h. 46

AFRODITE 2018-77
Pouf - *Pouf*
cm. 60 * 47 * h. 45



GEA
collection



by Bellotti Ezio



Walk-in closet







AFRODITE 2018-95
Cabina armadio - *Walk-in closet*

AFRODITE 2018-94
Pouf - *Pouf*
cm. 110 * 110 * h. 45



Dining





GEA
collection

“

La natura è assoluta: nelle sue linee, nei suoi colori, nelle sue parti, come nel suo insieme. Materiali e colori si combinano e si accordano offrendoci suggestioni che ci parlano di una vicinanza profonda: quella con il nostro habitat naturale.

Nature is absolute – in its lines, colours, parts, and as a whole. Materials and colours combine and come wonderfully together, offering emotions that speak to us of a deep-rooted relationship, our connection to our natural habitat.

”

PROMETEO 2018-54
Tavolo - Table
cm. Ø 140 * h. 72

FEBE 2018-57
Sedia in Noce Canaletto
Chair in Canaletto Walnut
cm. 49 * 54 * h. 92

DEMETRA 2018-58
Capotavola in Noce Canaletto
Chair with arms in Canaletto Walnut
cm. 60 * 64 * h. 85



GEA
collection



“

Il Noce Canaletto è impiegato per le parti in massello plasmate
assecondando le tensioni e le forze della struttura.

*Canaletto Walnut is used for solid moulded parts and follows
the tensions and forces of the frame.*

”



PROMETEO 2018-54
Tavolo - Table
cm. Ø 140 * h. 72

GEA
collection

“In tutte le cose della natura
esiste qualcosa di meraviglioso.”

Aristotele

*“In all things of nature there is
something wonderful.”*

Aristotele



GEA
collection

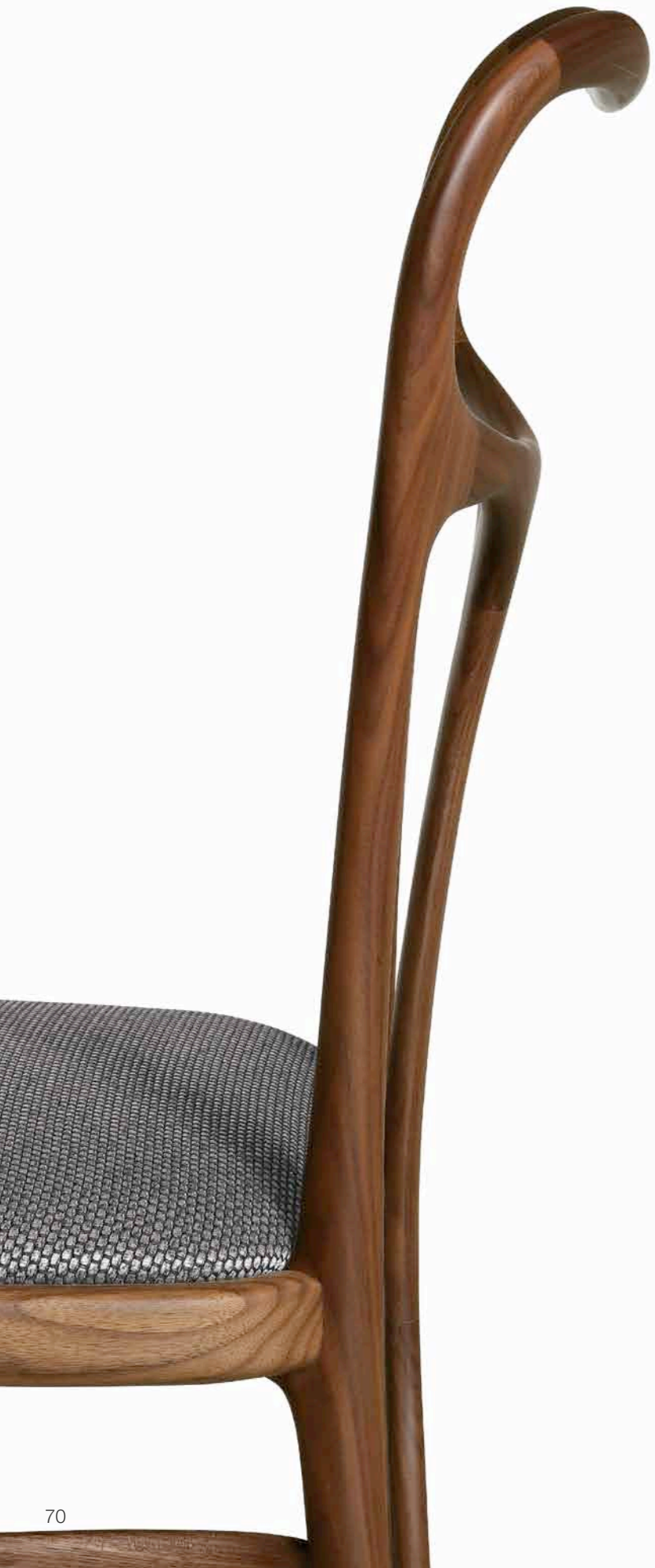

FEBE 2018-57
Sedia in Noce Canaletto
Chair in Canaletto Walnut
cm. 49 * 54 * h. 92



“

Semplicemente unica per disegno e leggerezza. Un incrocio di linee sinuose che ne scrivono la forma. Dalla struttura ricercata in massello di Noce Canaletto o in Frassino tinto a poro aperto.

Simply unique in its design and lightness – there is an intersection of sinuous lines that beautifully define its shape, thanks to the sophisticated frame in solid Canaletto Walnut or in open pore stained Ash.

”

GEA
collection



“

Una famiglia di contenitori dalle forme arrotondate. Caratterizzati dall'impiego di trame naturali proprie delle essenze impiegate: Ebano bianco e Ziricote. Le maniglie e i piedi sono veri e propri elementi scultorei.

An heritage of units with rounded shapes – these pieces are defined by the use of natural textures of the wood types used: white Ebony and Ziricote. The handles and the feet are tried and true sculptures.

”



ATENA 2018-46
Mobile in Ebano bianco
Sideboard in white Ebony
cm. 175 * 50 * h. 85

ATENA 2018-44
Specchiera - Mirror
cm. 153 * h. 100

GEA
collection



“

Dettagli raffinati, senza tempo.

Timeless, sophisticated details.

”

ATENA 2018-44
Specchiera - *Mirror*
cm. 153 * h. 100



GEA
collection



“

Essenze ricercate e calibrate attraverso tinte che ne esaltano e armonizzano le caratteristiche intrinseche.

The wood types are carefully selected and calibrated through colours that enhance and give harmony to their intrinsic characteristics.

”

ZEUS 2018-48
Mobile bar in Ebano bianco
Bar cabinet in white Ebony
cm. 110 * 55 * h. 180

GEA
collection



ZEUS 2018-48
Mobile bar in Ebano bianco
Bar cabinet in white Ebony
cm. 110 * 55 * h. 180

REA 2019-21
Poltrona in Frassino
Armchair in Ash wood
cm. 92 * 72 * h. 92

DEDALO 2019-28
Tavolino in Frassino
Small table in Ash wood
cm. 61 * 61 * h. 63



GEA
collection



ZEUS 2018-42
Mobile bar in Ziricote
Bar cabinet in Ziricote wood
cm. 110 * 55 * h. 180

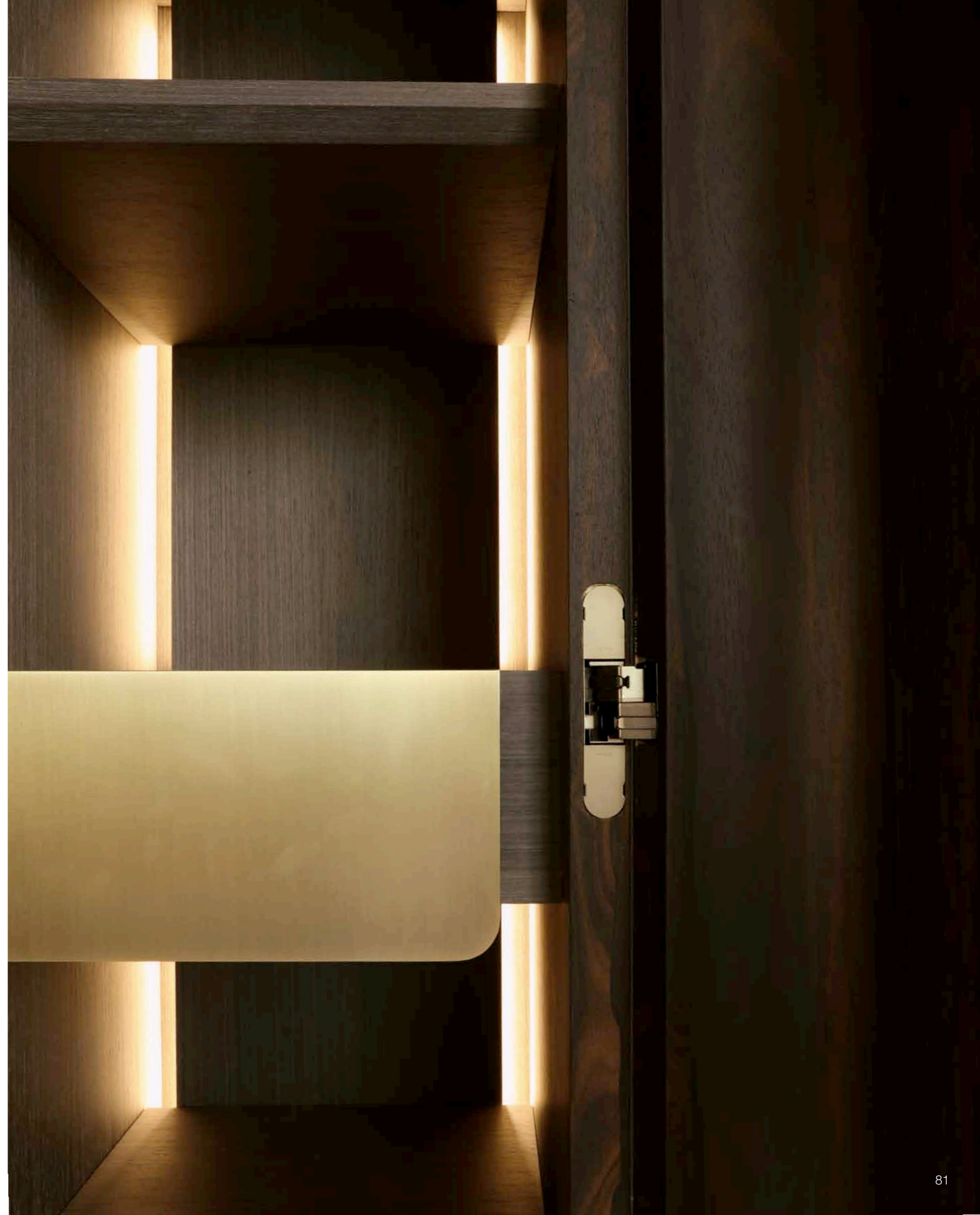

GEA
collection



ZEUS 2018-42
Mobile bar in Ziricote
Bar cabinet in Ziricote wood
cm. 110 * 55 * h. 180



Living





PATAGONIA 2019-25
Tavolino piano marmo Silver wave
Coffee table marble top Silver wave
cm. 140 * 60 * h. 26

PATAGONIA 2019-26
Tavolino piano marmo Calacatta Oro
Coffee table marble top Calacatta Gold
cm. 100 * 100 * h. 34

GEA
collection



ARES 2019-01
Divano 3 posti - 3 seats sofa
cm. 281 * 132 * h. 75

ARES 2019-03
Penisola - Chaise longue
cm. 133 * 90 * h. 75



GEA
collection

“

Piacere tattile e visivo si fondono nella stessa esperienza
per un'ergonomia delle emozioni.

*Tactile and visual pleasure come together in the same experience
for unmatched ergonomics.*

”



ARES 2019-05
Divano 3 posti - 3 seats sofa
cm. 245* 98 * h. 75

GEA
collection



PATAGONIA 2019-10
Tavolino piano marmo Calacatta Oro
Coffee table marble top Calacatta Gold
cm. 130 * 91 * h. 42



PATAGONIA 2019-12
Tavolino piano marmo Patagonia
Side table marble top Patagonia
cm. 70 * 70 * h. 71

“La Bellezza è una forma del Genio,
anzi, è più alta del Genio
perché non necessita di spiegazioni.”
Oscar Wilde

*“Beauty is a form of genius – is
higher, indeed, than genius, as it
needs no explanation.”
Oscar Wilde*







GEA
collection



PANGEA 2018-63
Mobile TV - TV cabinet
cm. 180 * 50 * h. 60



GEA
collection



PANGEA 2018-61
Vetrina - Glass cabinet
cm. 70 * 48 * h. 180

GEA
collection



“

Vivere l'eleganza, fin nel dettaglio.

Experience elegance, right down to the last detail.

”

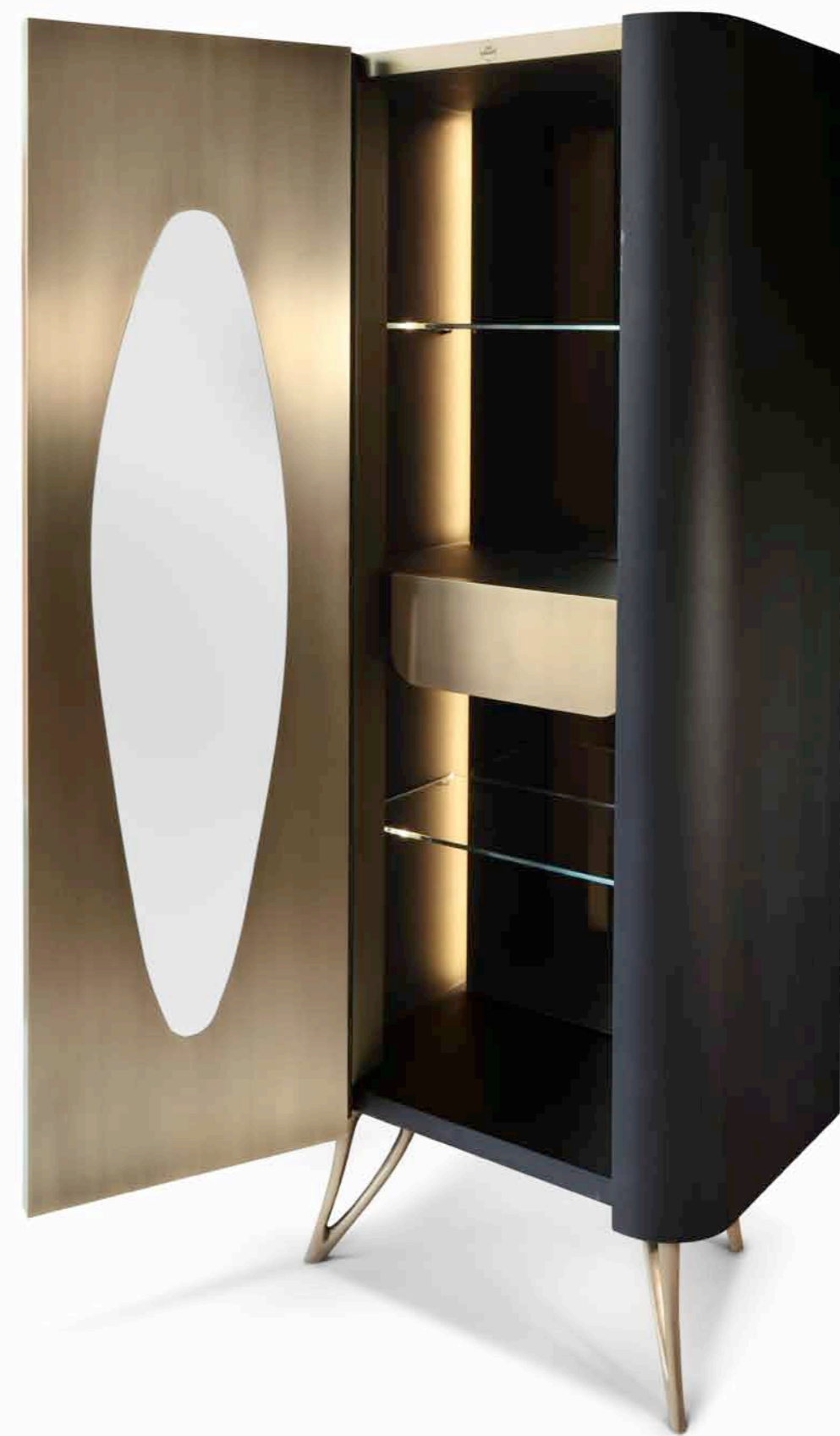

PANGEA 2018-61
Vetrina - Glass cabinet
cm. 70 * 48 * h. 180

GEA
collection



PANGEA 2018-49
Mobile TV - TV cabinet
cm. 180 * 50 * h. 60



GEA
collection



REA 2019-21
Poltrona in Frassino
Armchair in Ash wood
cm. 92 * 72 * h. 92

DEDALO 2019-30
Tavolino in Frassino
Small table in Ash wood
cm. 61 * 61 * h. 63



GEA
collection



DEDALO 2019-27
Tavolino in Noce Canaletto
Small table in Canaletto Walnut
cm. 61 * 61 * h. 63



DEDALO 2019-29
Tavolino in Noce Canaletto
Small table in Canaletto Walnut
cm. 61 * 61 * h. 63



DEDALO 2019-30
Tavolino in Frassino
Small table in Ash wood
cm. 61 * 61 * h. 63



DEDALO 2019-28
Tavolino in Frassino e piano in paglia cerata
Small table in Ash wood with waxed straw on the top
cm. 61 * 61 * h. 63



GEA
collection

“L’Arte è la mano destra
della natura”

Friedrich Schiller

*“Art is the right hand
of Nature”*

Friedrich Schiller



Bedroom





CRONO 2018-70
Letto in Noce Canaletto
Bed in Canaletto Walnut
cm. 236 * 240 * h. 143

GEA
collection

“

Il letto Crono è caratterizzato dalla forza delle linee sinuose che lo definiscono. La testiera è fatta da una struttura in legno che fa da supporto alla parte imbottita con un elegante capitonné sul quale sono in evidenza i bottoni in essenza coordinati alla struttura. La pediera è in pelle con cuciture a vista. I supporti della pediera sono vere e proprie sculture in fusione di ottone con finitura bronzata.

The Crono bed is wonderfully defined by the strength of its sinuous lines. The headboard is made of a wooden frame that acts as a support to the upholstered part with an elegant button tufting, highlighted by the wooden buttons coordinated with the frame. The footboard is in leather with visible stitching. The footboard supports are true sculptures in brass casting with bronze finish.

”

CRONO 2018-70
Letto in Noce Canaletto
Bed in Canaletto Walnut
cm. 236 * 240 * h. 143

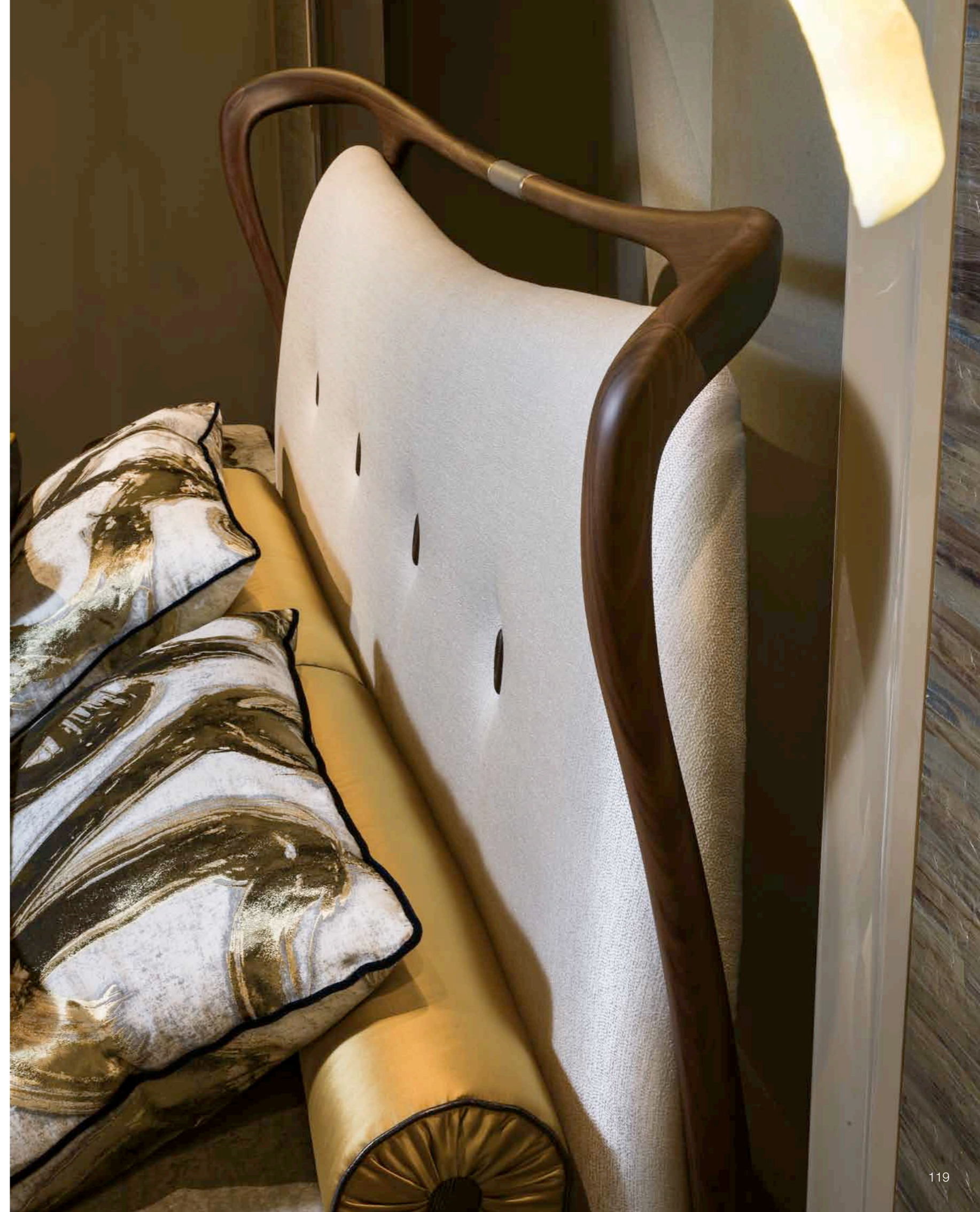



GEA
collection



LAPETO 2018-73
Comodino - Night table
cm. 65 * 46 * h. 57

GEA
collection



“

Semplice e dalla forma arrotondata. Un contenitore in noce canaletto sospeso su quattro piedi scultorei in ottone bronzato. Il piano è in marmo di Patagonia.

Simple and rounded shape. A storage unit in Canaletto walnut suspended on four sculpted feet in bronze-finished brass. The top is in Patagonian marble.

”



LAPETO 2018-73
Comodino - *Night table*
cm. 65 * 46 * h. 57

GEA
collection



“

I dettagli esprimono più della vista d'insieme.

Details express more than what we see in its entirety.

”



LAPETO 2018-73PL
Comodino - *Night table*
cm. 65 * 46 * h. 57

GEA
collection

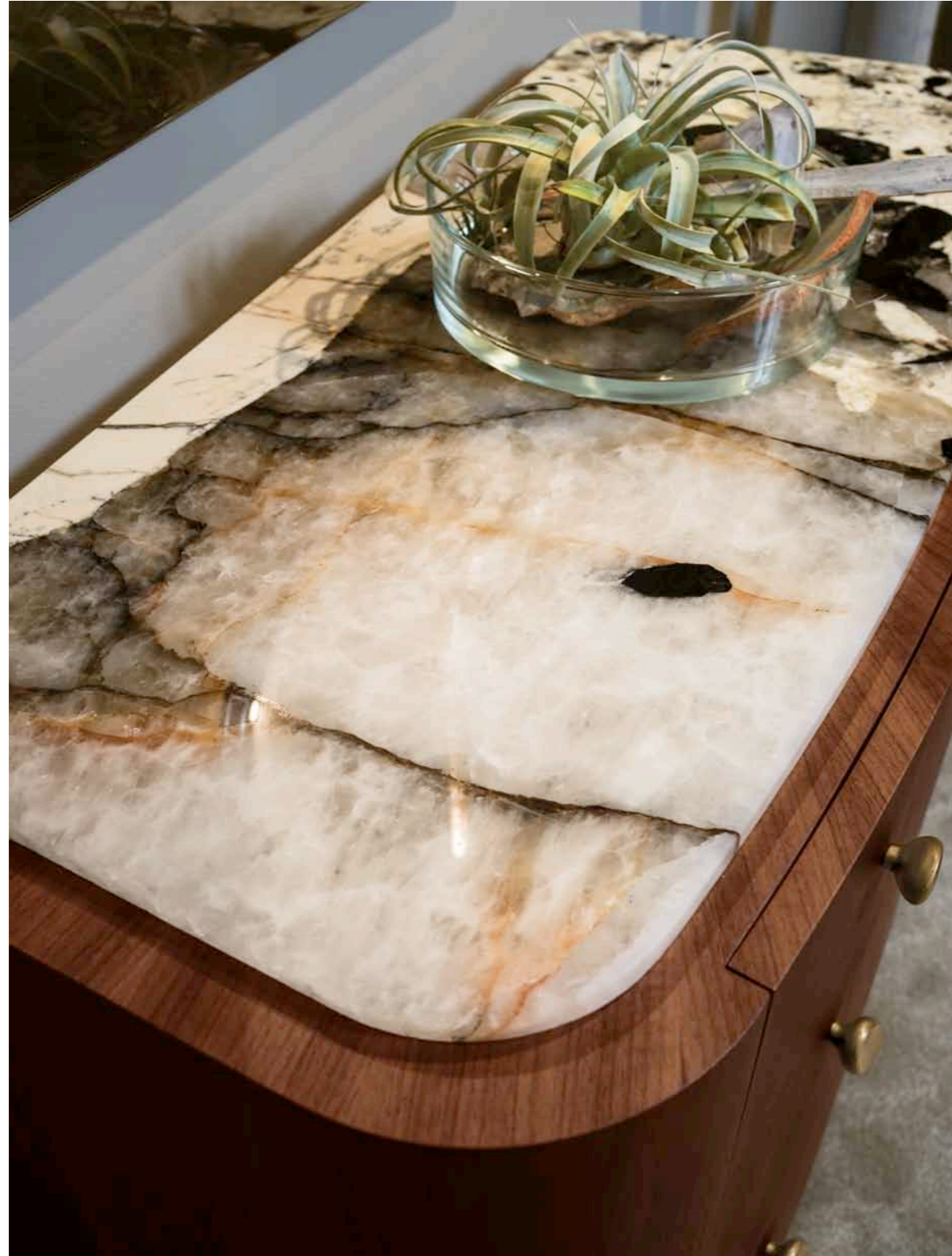

LAPETO 2018-71
Comò - Chest of drawers
cm. 120 * 56 * h. 88

LAPETO 2018-72
Specchiera - Mirror
cm. 77 * h. 122



GEA
collection



LAPETO 2018-72
Specchiera - *Mirror*
cm. 77 * h. 122



AFRODITE 2018-74
Consolle trucco - Vanity
cm. 125 * 46 * h. 76

AFRODITE 2018-75
Specchiera - Mirror
cm. 30 * 20 * h. 46

AFRODITE 2018-77
Pouf - Pouf
cm. 60 * 47 * h. 45

“

La struttura della consolle trucco è in Noce Canaletto con il piano laccato e in parte rivestito in pelle con cuciture a vista. Il cassetto, come altri dettagli, è in ottone bronzato.

The frame of the vanity dresser is in Canaletto Walnut with a lacquered top partly covered in leather with visible stitching. The drawer, like all the other details, is in bronze-finished brass.

”





AFRODITE 2018-77
Pouf - *Pouf*
cm. 60 * 47 * h. 45

SELENE 2018-76
Dormeuse - *Dormeuse*
cm. 182 * 97 * h. 74

GEA
collection



“

Il design innovativo mette in evidenza le curvature
e le cuciture nella pelle.

*Innovative design highlights the wonderful curvatures
and seams in the leather.*

”



STONE 2019-50
Poltrona - *Armchair*
cm. 125 * 105 * h. 68

STONE 2019-51
Pouf - *Pouf*
cm. 90 * 60 * h. 35

STONE 2019-52
Divano - *Sofa*
cm. 220 * 105 * h. 68



Living



“

La forma senza tempo delle emozioni.

The timeless form of emotions.

”



EGEO 2019-55
Poltrona - *Armchair*
cm. 110 * 90 * h. 80



EGEO 2019-57
Divano 3 posti - *3 seats sofa*
cm. 270 * 90 * h. 80

EGEO 2019-58
Divano ad angolo
Corner sofa
cm. 270+270 * 90 * h. 80





DELFI
collection

Una linea contemporanea di arredi disegnati dall'architetto Giovanni Luca Ferreri che richiama le origini della Modernità.

Colori e storie che raccontano le origini di una cultura figurativa ricca di suggestioni, ispirate alla natura dei luoghi e delle loro genti. Nei dettagli della nuova linea Delfi si trovano i rimandi all'arte e alla cultura Ellenica: per esempio le briglie del famoso capolavoro, l'Auriga di Delfi, diventano il tema per un dettaglio che caratterizza la base dei mobili contenitore.

This contemporary line of furnishings, designed by architect Giovanni Luca Ferreri, beautifully conjures up the true origins of Modernity.

Colors and stories that tell the origins of a figurative culture rich in suggestions, inspired by the nature of the place and their people. The details of the new Delfi line include references to Hellenic art and culture: for example, the bridle of the famous masterpiece, the Auriga of Delfi, becomes the theme for a detail that characterizes the base of the furniture.

Hall



DELFI
collection



“

Il dettaglio è anche citazione. Nella consolle la struttura di sostegno è chiusa alla base dalle “briglie” in metallo che riprendono il gesto dell’Auriga.

The detail is also a quote. In the console the support structure is closed to the base by the “metal bridges” that take on the gesture of the Auriga.

”

AURIGA 2018-24
Consolle - Console
cm. 130 * 47 * h. 92

AURIGA 2018-25
Specchiera - Mirror
cm. 84 * h. 84





DELFI
collection



“

Uno specchio di proporzioni quadrate ispirato all'arte moderna.
Nella sua versione in bronzo la parte riflettente è scavata
nella superficie.

*A mirror of square proportions inspired by modern art.
In its bronze version the reflective part is dug into the surface.*

”

AURIGA 2018-25
Specchiera - *Mirror*
cm. 84 * h. 84

DELFI
collection

“

La consolle OMERO è la combinazione perfetta con
la specchiera. Insieme formano un unico oggetto protagonista
all'interno di uno spazio domestico.

*The OMERO console is the perfect combination with the mirror.
Together they form a single protagonist object within a domestic space.*

”

OMERO 2018-08
Consolle - Console
cm. 128 * 48 * h. 96

OMERO 2018-09
Specchiera - Mirror
cm. 91 * 17 * h. 135



DELFI
collection

“

La specchiera OMERO è una figura dalle linee organiche che riprendono la figura classica. Forma e struttura trovano la sintesi nella specchiera e consolle OMERO.

The OMERO mirror is the figure with organic lines that resemble the classic figure. Shape and structure find the synthesis in the OMERO mirror and console

”

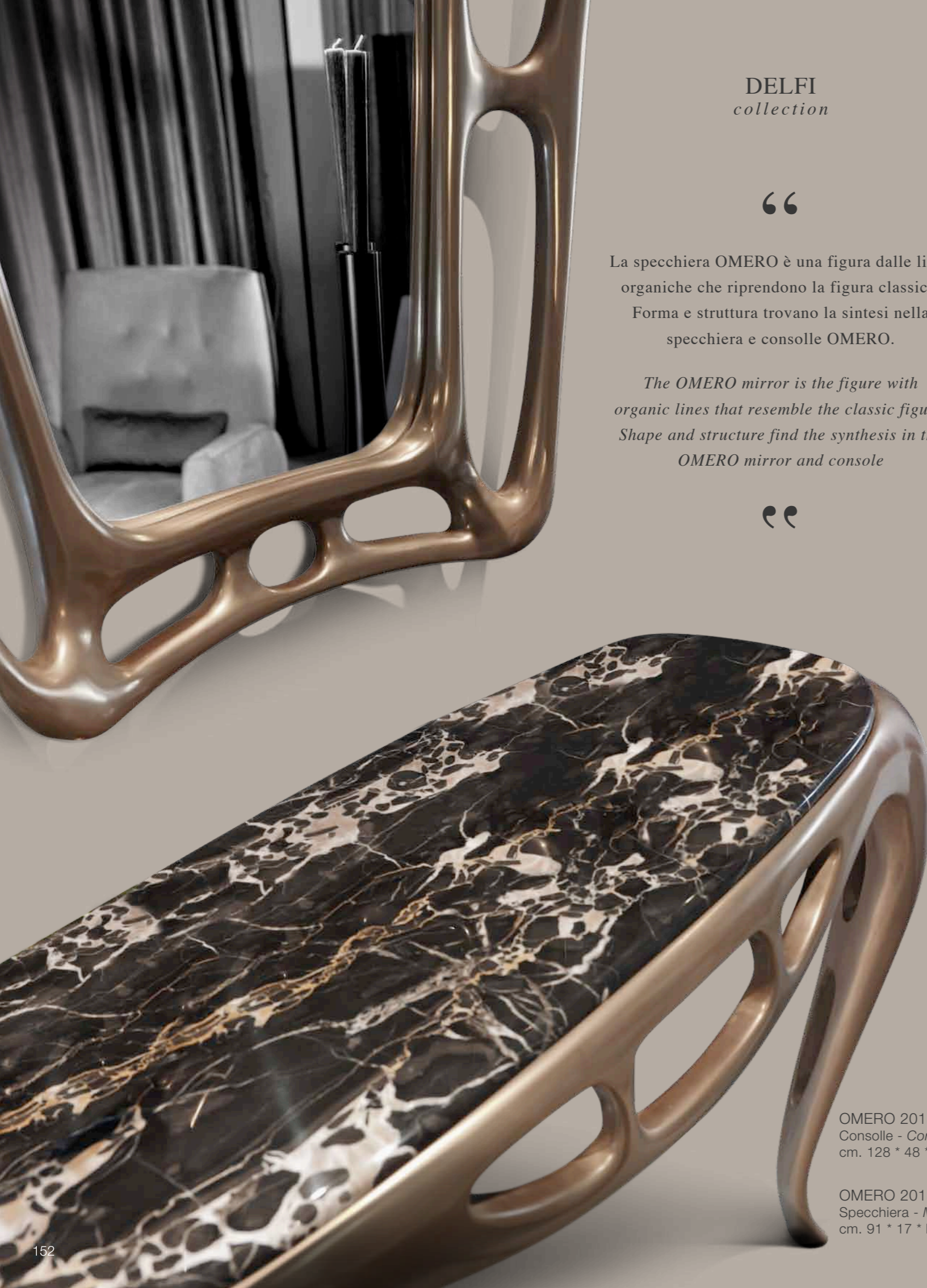

OMERO 2018-06
Consolle - Console
cm. 128 * 48 * h. 96

OMERO 2018-07
Specchiera - Mirror
cm. 91 * 17 * h. 135



Dining



DELFI
collection

DELFI
collection



AURIGA 2018-30
Tavolo - *Table*
cm. 230 * 110 * h. 76

ICO 2018-32
Sedia - *Chair*
cm. 54 * 57 * h. 95

DELFI
collection



“

Semplice ed arcaico come deve essere un tavolo che guarda alle figure classiche. La sua struttura in legno di frassino sostiene un piano in marmo.

Simple and archaic as it should be a table looking at classic. Its ash wood structure supports a marble top.

”



AURIGA 2018-30
Tavolo - Table
cm. 230 * 110 * h. 76

DELFI
collection



“

Raffinata ed estremamente confortevole, la sedia ICO ha un disegno di ispirazione classica reinterpretato da Bel Mondo.

Refined and extremely comfortable, the ICO chair has a classical inspired design, reinterpreted by Bel Mondo.

”



ICO 2018-32
Sedia - Chair
cm. 54 * 57 * h. 95



AURIGA 2018-20
Mobile - Sideboard
cm. 197 * 48 * h. 91

DELFI
collection



DELFI
collection

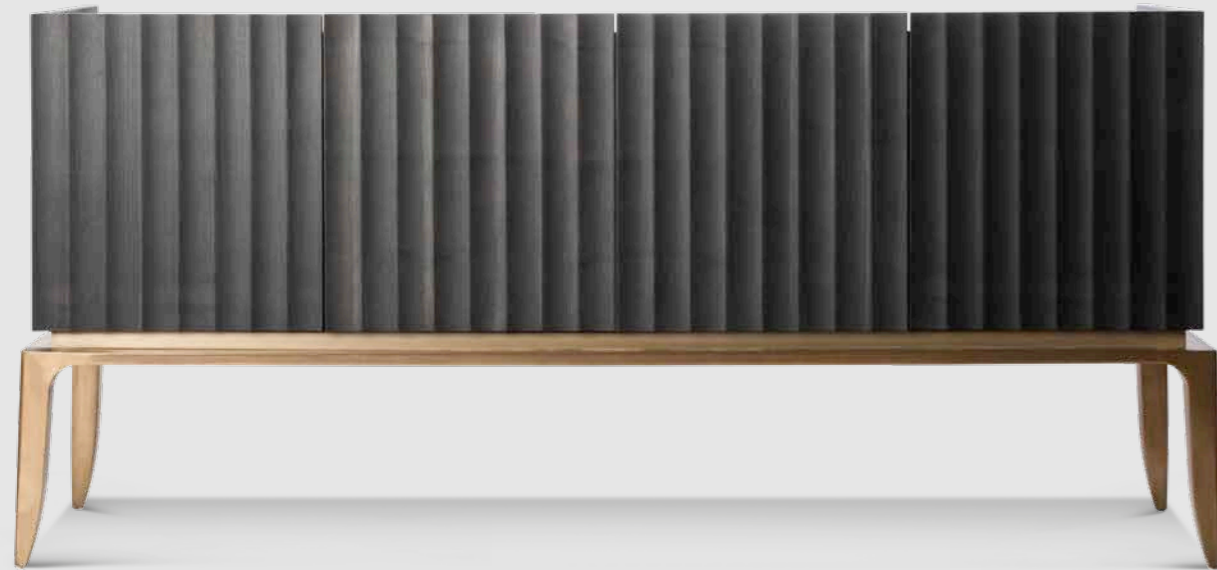

“

L'euritmia del chiaroscuro esalta le venature del legno.
I dettagli in ottone bronzato impreziosiscono tutta la collezione.

*The chiaroscuro euristics exalts the grain of wood.
Bronzed brass details embellish the entire collection.*

”

AURIGA 2018-20
Mobile - Sideboard
cm. 197 * 48 * h. 91



DELFI
collection



by Bellotti Ezio

AURIGA 2018-31
Tavolo - Table
cm. 300 * 120 * h. 76

ICO 2018-32
Sedia - Chair
cm. 54 * 57 * h. 95





MEDITA 2018-01
Poltrona - *Armchair*
cm. 90 * 88 * h. 108

AURIGA 2018-31
Tavolo - *Table*
cm. 300 * 120 * h. 76

ICO 2018-32
Sedia - *Chair*
cm. 54 * 57 * h. 95



DELFI
collection



AURIGA 2018-21
Vetrina - Glass cabinet
cm. 215 * 52 * h. 211

FICUS
collection

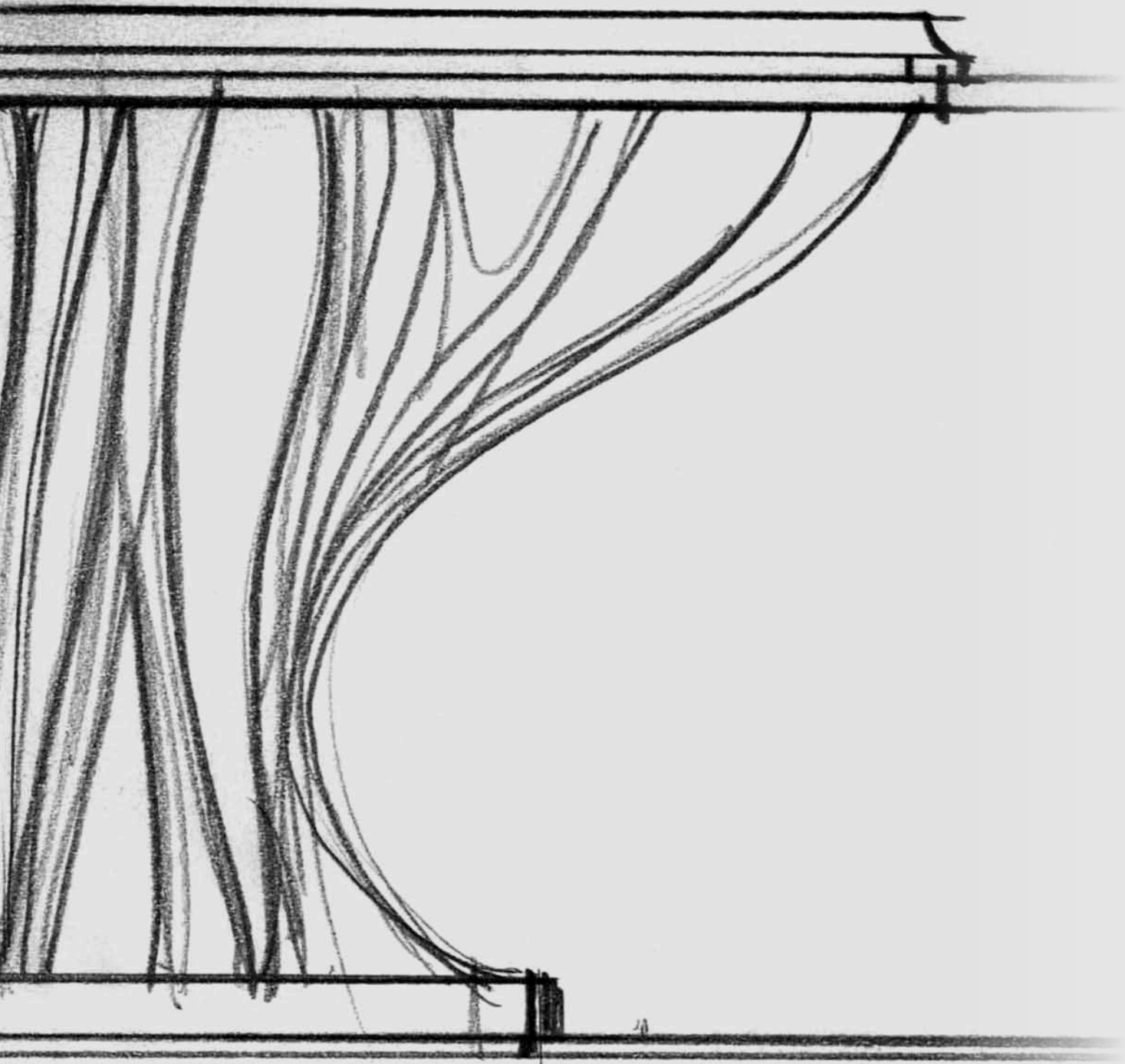

FICUS 2016-42
Tavolo - *Table*
cm. Ø 160 * h. 76



FICUS
collection



FICUS 2016-42
Tavolo - Table
cm. Ø 160 * h. 76

ICO 2018-32
Sedia - Chair
cm. 54 * 57 * h. 95

DELFI
collection



ICO 2018-32
Sedia - Chair
cm. 54 * 57 * h. 95

Living





2016-46
Divano 3 posti - 3-seats sofa
cm. 260 * 108 * h. 78

MILETO 2018-14
Tavolino - Coffee table
cm. 110 * 110 * h. 41



ATTESA 2018-10
Poltrona - Armchair
cm. 93 * 87 * h. 73

PLEIADI 2018-04
Tavolino - Coffee table
cm. 110 * 110 * h. 25

2016-49
Tavolino rotondo - Round coffee table
cm. Ø 73 * h. 69



AURIGA 2018-19
Mobile - Sideboard
cm. 197 * 48 * h. 91

DELFI
collection



DELFI
collection



AURIGA 2018-22
Mobile bar - Bar cabinet
cm. 113 * 53 * h. 166

2018-17
Sistema di sedute - Seating system
cm. 340+350 * 108 * h. 78

AURIGA 2018-18
Pouff - Pouf
cm. 130 * 90 * h. 45

DELFI
collection



by Bellotti Ezio





DELFI
collection

2016-46
Divano - *Sofa*
cm. 260 * 108 * h. 78

TESEO 2018-13
Poltrona - *Armchair*
cm. 73 * 77 * h. 78

PLEIADI 2018-03
Tavolino - *Coffee table*
cm. 110 * 110 * h. 25/55



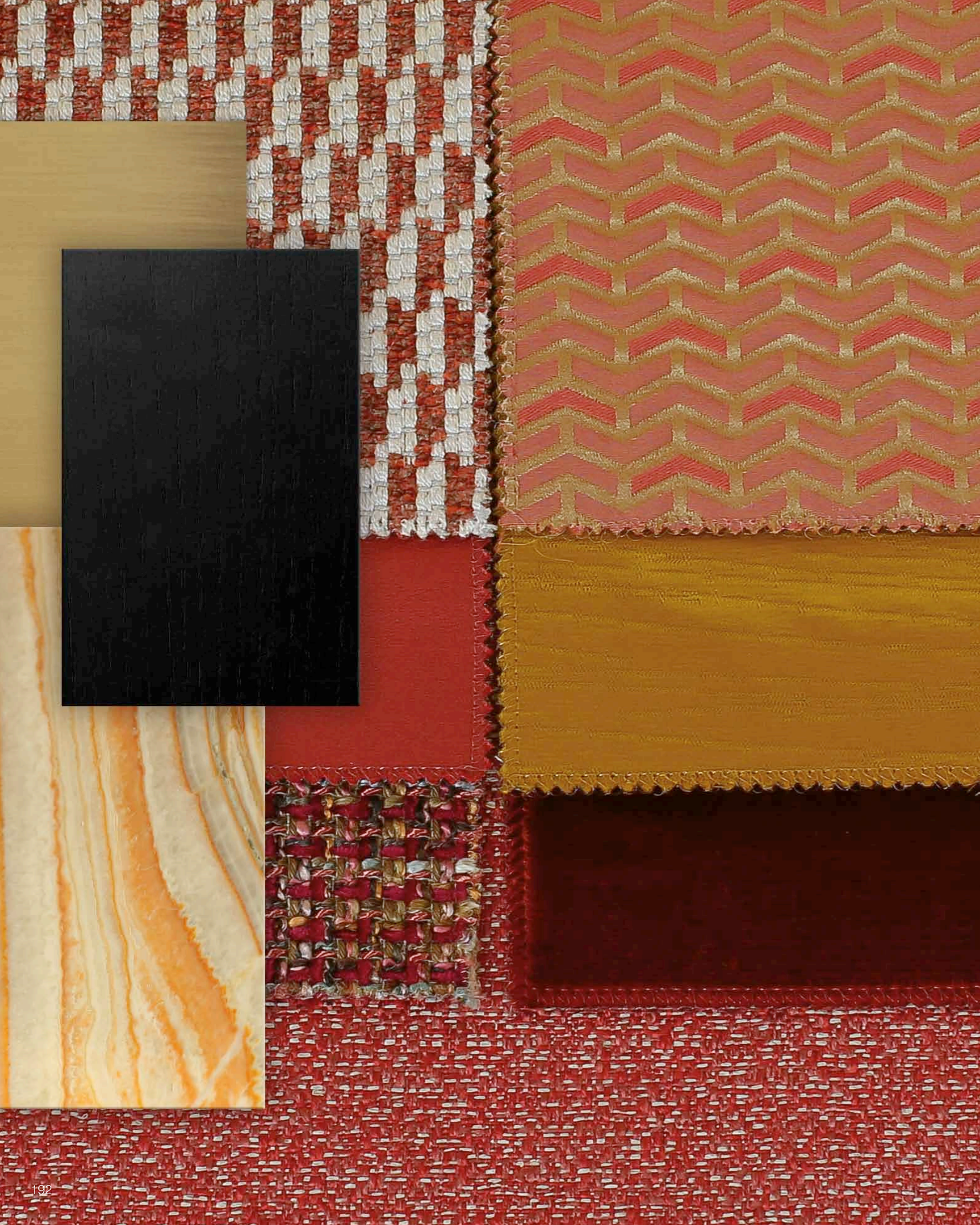

DELFI
collection

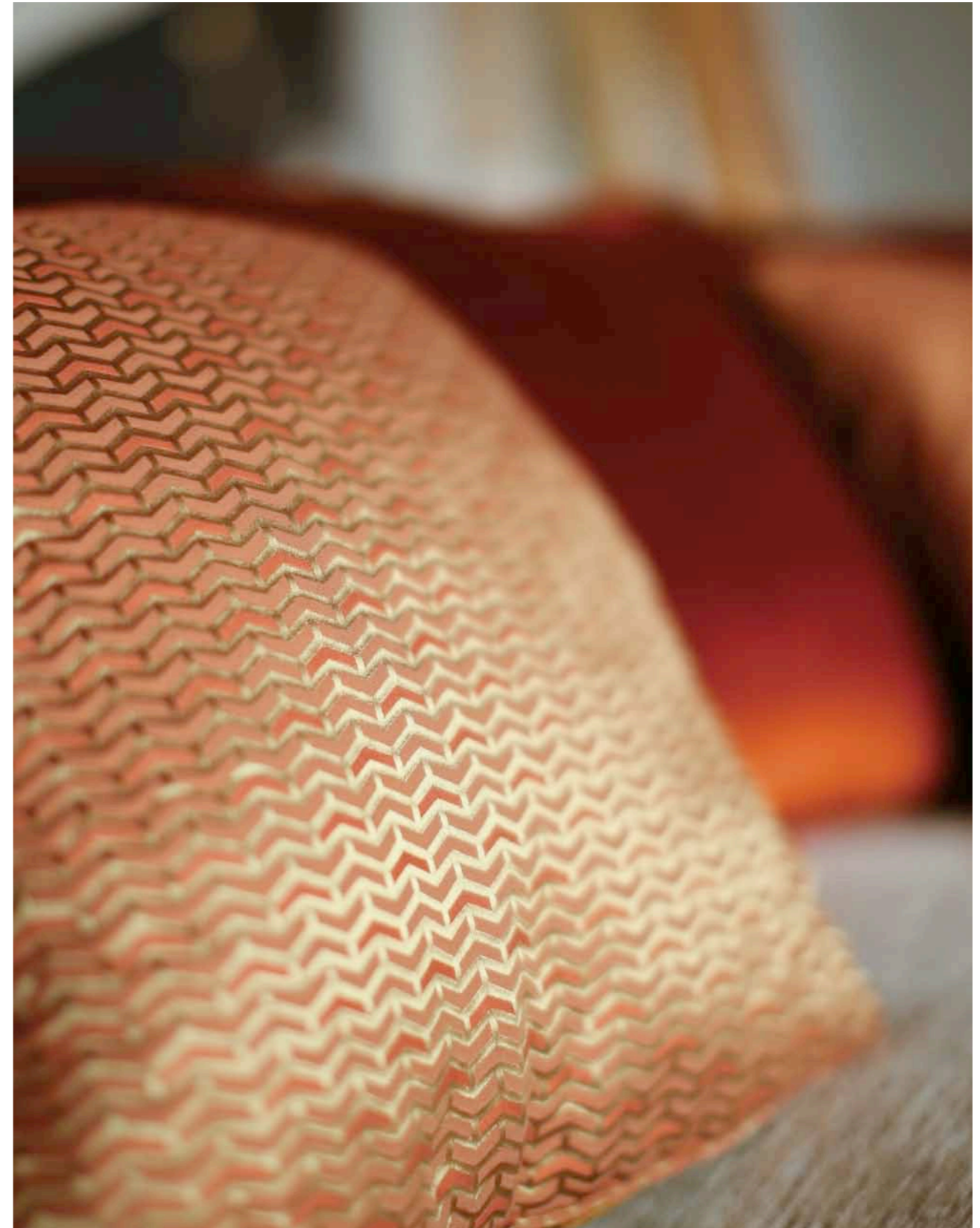

DELFI
collection



“

Il coffee-table PLEIADI si ispira ad un'area geografica dove mito e storia vivono gli stessi luoghi. Due isole sospese che ruotano a formare diverse geometrie possibili.

The coffee-table PLEIADI is inspired by a geographical area where myth and history live in the same places. Two suspended islands rotating to form different possible geometries.

”



PLEIADI 2018-03
Tavolino - Coffee table
cm. 110 * 110 * h. 25/55

DELFI
collection



DELFI
collection



“

Classica e allo stesso tempo moderna, comoda e accogliente
nella sua forma: MEDITA è un luogo su cui sedersi.

*Classic yet modern, comfortable and welcoming: MEDITA is a
place to sit on.*

”

MEDITA 2018-01
Poltrona - Armchair
cm. 90 * 88 * h. 108

DELFI
collection



by Bellotti Ezio



DELFI
collection



“

ATTESA è semplicemente chic e trasmette la sua
eleganza a qualsiasi ambiente.

ATTESA is simply chic and instills elegance to any setting.

”



ATTESA 2018-10
Poltrona - Armchair
cm. 93 * 87 * h. 73



TESEO 2018-13
Poltrona - Armchair
cm. 73 * 77 * h. 78

DELFI
collection



“

Dal disegno deciso e chiaro, la poltrona TESEO è una seduta semplice la cui linea esprime l'essenziale.

Clear and decided design. TESEO armchair is a simple seat whose line expresses the essence.

”

DELFI
collection



by Bellotti Ezio



DELFI
collection



DELFI
collection



“

Un coffee-table che è anche libreria. La struttura in Frassino tinto ha proporzioni auree. Il piano è come il tracciato di una città. Al centro un inserto di preziosa sodalite.

A coffee-table that is also a bookstore. The structure in stained ash has a gold proportions. The plan is like a city map. At the center a precious sodalite detail.

”



MILETO 2018-14
Tavolino centrale - Coffee table
cm. 110 * 110 * h. 41

MILETO 2018-16
Tavolino laterale piano legno
Side table wooden top
cm. 60 * 60 * h. 71

DELFI
collection



DELFI
collection



“

La serie dei contenitori DELFI è caratterizzata da un motivo geometrico tridimensionale che evoca il drappeggio dei capolavori della cultura Ellenica.

The DELFI container series is characterized by a three-dimensional geometric pattern which evokes the draping of the masterpieces of Hellenic culture.

”



AURIGA 2018-28
Mobile bar - Bar cabinet
cm. 112 * 52 * h. 185

DELFI
collection



“

L'ineguagliabile artigianato italiano raggiunge un'estrema
sostituzione nel mobile bar AURIGA.

*Unparalleled italian craftsmanship is extremely sophisticated
in the AURIGA bar cabinet.*

”

AURIGA 2018-23
Mobile bar - Bar cabinet
cm. 113 * 53 * h. 166

Bedroom





DELFI
collection



by Bellotti Ezio



LEVANTE 2017-36
Letto - Bed
cm. 213 * 222 * h. 227

FRINE 2017-43
Panchetta - Bench
cm. 130 * 52 * h. 46

DELFI
collection



“

Il letto a baldacchino è disegnato da una struttura elegante ed eterea. I quattro elementi verticali in legno di frassino sostengono l'elemento di chiusura in ottone sul quale scorrono le tende a velo.

The canopy bed is designed by an elegant and ethereal structure. The four vertical elements in ash wood support the brass closing element on which the voile curtains slide.

”

DELFI
collection



“

Lussuoso e sobrio, il comodino LEPANTO aggiunge valore ad ogni ambiente. Il rivestimento in nabuk e i dettagli in ottone bronzato conferiscono all'oggetto carattere ed eleganza.

Luxurious and sober, the LEPANTO bedside table adds value to any space. The nabuk and bronzed brass details give the object character and elegance.

”

LEPANTO 2017-31
Comodino - *Night table*
cm. 70 * 51 * h. 68





LEPANTO 2017-32
Comò - Chest of drawers
cm. 125 * 54 * h. 88

LEPANTO 2018-27
Specchiera - Mirror
cm. 87 * h. 105

DELFI
collection

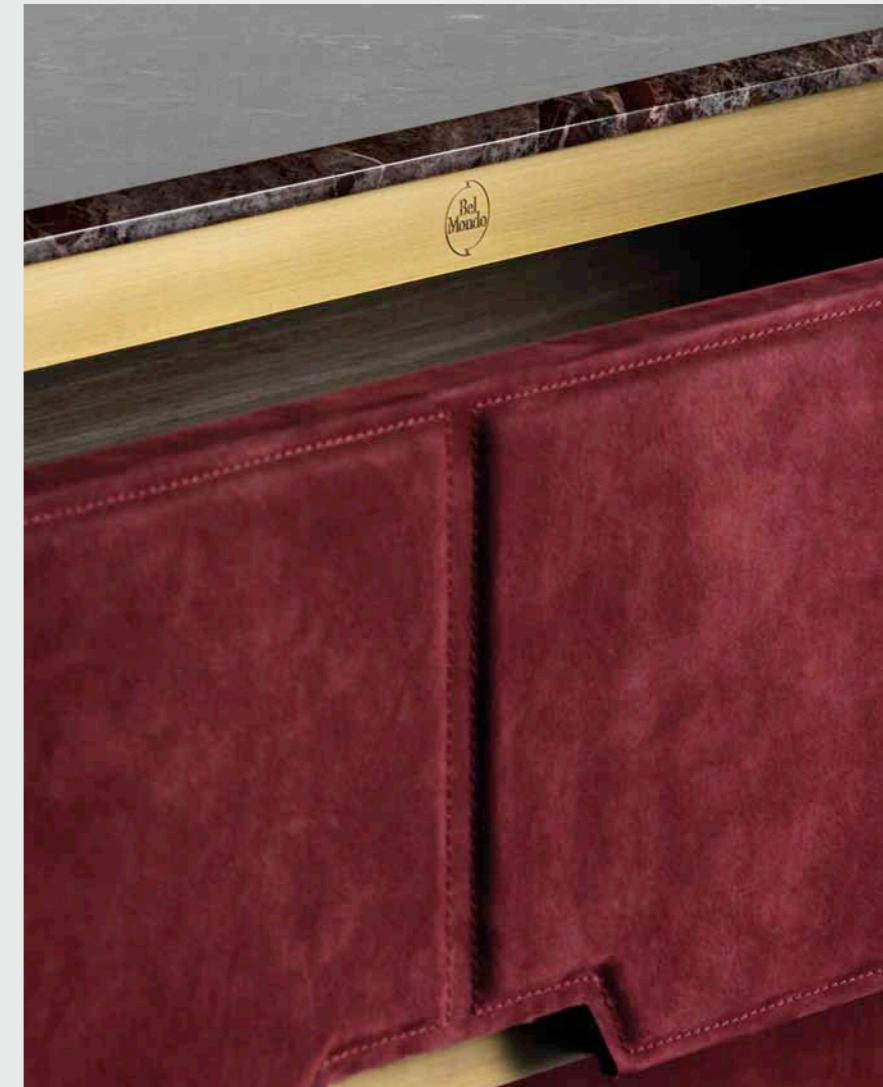

“

Comò e specchiera della camera da letto LEPANTO rappresentano una combinazione unica. Lusso e design si incontrano in questa collezione.

LEPANTO's chest of drawers and mirror are a unique combination. Luxury and design come together in this collection.

”

DELFI
collection



“

Prezioso ed elegante, il vanity FRINE completa l'allestimento della camera da letto. Essenziale e comodo. Un pouf disegnato per accompagnare il vanity FRINE.

Precious and elegant, the vanity FRINE completes the bedroom layout. Simple and comfortable. A pouf designed to accompany the vanity FRINE.

”



FRINE 2017-33
Consolle trucco - Vanity
cm. 135 * 51 * h. 75

FRINE 2017-42
Pouf
cm. 47 * 47 * h. 45



DELFI
collection



NAXOS 2017-48
Armadio - Wardrobe
cm. 130 * 70 * h. 210

DELFI
collection



“

Il nostro armadio-guardaroba NAXOS presenta porte dalla particolare forma austera ed elegante.

Our NAXOS wardrobe features doors with peculiar design and elegance.

”

NAXOS 2017-48
Armadio - Wardrobe
cm. 130 * 70 * h. 210

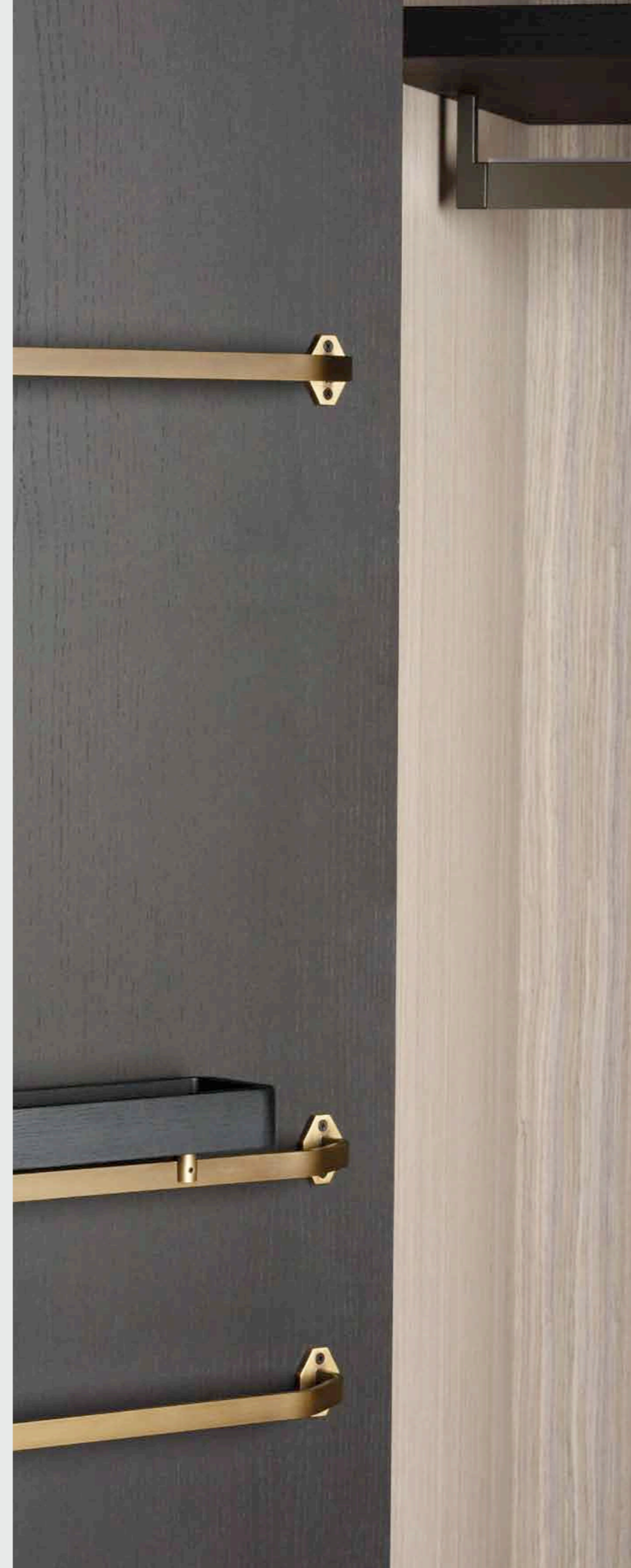

DELFI
collection



LEVANTE 2017-36
Letto - Bed
cm. 213 * 222 * h. 227

LEPANTO 2017-31
Comodino - Night table
cm. 70 * 51 * h. 68

FRINE 2017-43
Panchetta - Bench
cm. 130 * 52 * h. 46

TESEO 2018-13
Poltrona - Armchair
cm. 73 * 77 * h. 78

2018-05
Tavolino - Coffee table
cm. 120 * 65 * h. 40

Lighting



DELFI
collection



“

Gli ELMI sono una serie di lampadari decorativi con struttura in metallo bronzato e vetro soffiato a mano realizzati a Murano.

ELMI are a series of decorative chandeliers, with bronzed metal frame and hand blown glass made in Murano.

”



ELMI 06
Lampadario - Chandelier
cm. 112 * 60 * h. 80

DELFI
collection



“

Grazie alla singolare texture della parte in vetro danno una particolare vibrazione alla luce. Nella versione a soffitto sono disponibili a tre e sei luci.

The particular texture of the glass part give a special vibration to the light. In the pendant version are available with three or six lights.

”

ELMI 03
Lampadario - Chandelier
cm. Ø 50 * h. 70

DELFI
collection



“

Gli ELMI sono anche in versione applique. Sono disponibili in diverse finiture sia per la struttura che per il colore del vetro.

The ELMI are also in applique version. They are available in different finishes for both the structure and the color of the glass.

”

ELMI 01
Applique - Wall light
cm. 25 * 41 * h. 65

DELFI
collection



“

In questi lampadari la sapienza artigianale del vetro muranese incontra le linee contemporanee della collezione DELFI.

In these chandeliers the craftsmanship of Murano glass meets the contemporary lines of the DELFI collection.

”

ELMI 09
Lampadario - Chandelier
cm. Ø 80 * h. 70

DELFI
collection



“

La lampada da tavolo della serie ELMI è caratterizzata da una struttura che riprende il design dei corpi sospesi.

The table lamp of the ELMI series is characterized by a structure that evokes the design of the chandeliers.

”

ELMI 10
Lumetto da comodino - Night table lamp
cm. Ø 22 * h. 45

DELFI
collection



“

Degli elementi pendenti da accoppiare e distribuire per creare suggestive composizioni.

Some hanging elements to match and distribute to create suggestive compositions.

”

ACHEI 11
Lampadario - *Chandelier*
cm. Ø 20 * 220-190 * h. 160



GEA
collection

Technical information

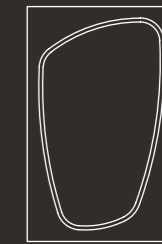
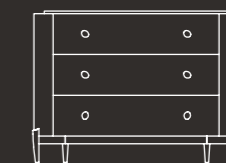
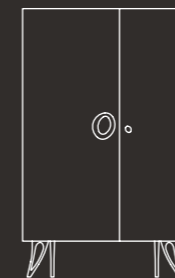

GEA
collection

ATENA 2018-40

Mobile con struttura in multistrato impiallacciato in Ziricote, finitura opaca con piano marmo Patagonia. Piedini scultorei, pomoli ed elementi interni in ottone finitura bronzo chiaro opaco. Luci a led interne.

Sideboard structure in plywood veneered with Ziricote wood matt finished, marble top Patagonia. Sculptural feet, knobs and internal elements in light bronzed matt brass. Led lights inside

Pag. 33

cm. 175 * 50 * h. 85

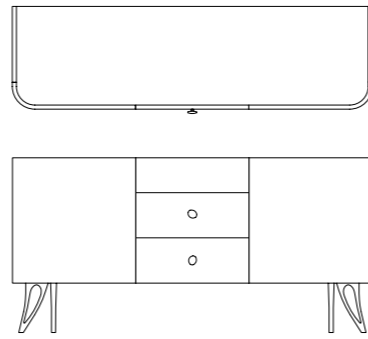

ATENA 2018-46

Mobile con struttura in multistrato impiallacciato in Ebano bianco lucidato poliestere con piano marmo Silver Wave. Piedini scultorei, pomoli ed elementi interni in ottone finitura nichel scuro. Luci a led interne.

Sideboard structure in plywood veneered with white Ebony polyester polished, marble top Silver wave. Sculptural feet, knobs and internal elements in dark nichel finished. Led lights inside.

Pag. 73

cm. 175 * 50 * h. 85

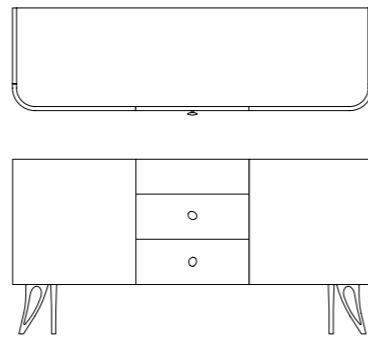

ZEUS 2018-42

Mobile bar con struttura in multistrato impiallacciato in Ziricote finitura opaca. Piedini scultorei, maniglie ed elementi interni in ottone finitura bronzo chiaro opaco. Luci a led interne.

Bar cabinet structure in plywood veneered with Ziricote wood, matt finished. Sculptural feet, handles and internal elements in light bronzed matt brass. Led lights inside.

Pag. 24 - 80 - 82

cm. 110 * 55 * h. 180

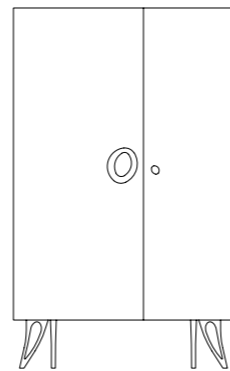

ZEUS 2018-48

Mobile bar con struttura in multistrato impiallacciato in Ebano bianco lucidato poliestere. Piedini scultorei, maniglie ed elementi interni in ottone finitura nichel scuro. Luci a led interne.

Bar cabinet structure in plywood veneered with white Ebony polyester polished. Sculptural feet, handles and internal elements in brass, dark nichel finished. Led lights inside.

Pag. 76 - 78

cm. 110 * 55 * h. 180

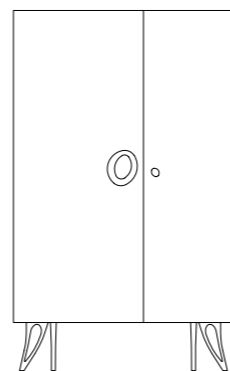

GEA
collection

PANGEA 2018-61

Vetrina con struttura impiallacciata in Frassino tinto grigio ed anta laccata poliestere. Parte interna dell'anta, elementi e piedini scultorei in ottone finitura bronzo chiaro opaco. Luci a led interne.

Glass cabinet structure veneered in grey stained Ash, door polyester polished. Internal part of door, elements and sculptural feet in light bronzed matt brass. Led lights inside.

Pag. 100

cm. 70 * 48 * h. 180

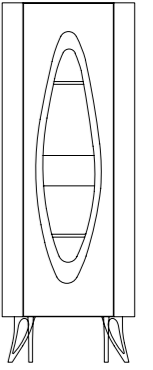

PANGEA 2018-63

Mobile TV con struttura impiallacciata in Frassino tinto grigio e cassetto centrale laccato poliestere, piano marmo Dover white. Piedini scultorei ed elementi interni in ottone finitura bronzo chiaro opaco.

TV cabinet structure veneered in grey stained Ash, central drawer polyester polished, marble top Dover white. Sculptural feet and internal elements in light bronzed matt brass.

Pag. 29 - 98

cm. 180 * 50 * h. 60

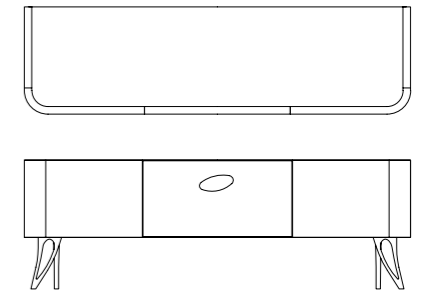

PANGEA 2018-49

Mobile porta TV finitura laccato poliestere con piano marmo Dover white. Piedini scultorei ed elementi interni in ottone finitura bronzo chiaro opaco.

TV cabinet polyester polished with marble top Dover white. Sculptural feet and internal elements light bronzed matt brass.

Pag. 105

cm. 180 * 50 * h. 60

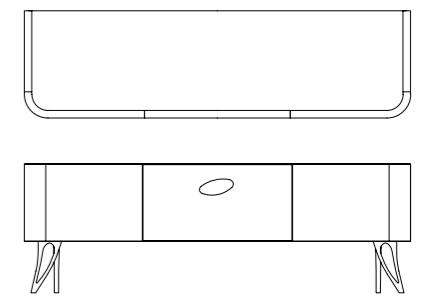

GEA
collection

DOLOMIA 2018-50C

Elemento contenitore squadrato con struttura in multistrato impiallacciato in Noce Canaletto finitura opaca, anta push pull.
Squared element structure in plywood veneered with Canaletto Walnut, internal shelves matt finished, push-pull door.

Pag. 34 - 38



DOLOMIA 2018-50S

Scaffale in tubolare metallico finitura bronzata con mensole, cassetti e cassettoni impiallacciati in Noce Canaletto finitura opaca.
Shelf unit in tubular metal bronzed finished with shelves and drawers veneered in Canaletto Walnut matt finished.

Pag. 34 - 38

cm. 150 * 41 * h. 285

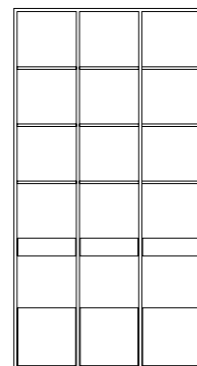

DOLOMIA 2018-50R

Boiserie retro scaffale in lamina di ottone, finitura bronzo chiaro opaco composta a scacchiera.
Back panel of boiserie in foil sheets, light bronze matt brass composed in chessboard.

Pag. 38



DOLOMIA 2018-50BT

Pannelli di boiserie verticali in multistrato rivestiti in tessuto con bordura perimetrale in ottone 5 mm.
Vertical panels of boiserie in plywood covered in fabric with perimetral brass border 5 mm.

Pag. 34 - 38



GEA
collection

DOLOMIA 2018-50BC

Boiserie in multistrato impiallacciato in Noce Canaletto finitura opaca.
Boiserie in plywood veneered with Canaletto Walnut, matt finished.

Pag. 35 - 38

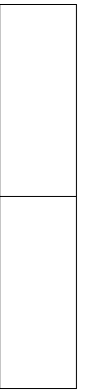

PROMETEO 2018-55

Tavolo rettangolare con base in massello di Frassino tinto grigio, piano in cristallo.
Rectangular table with base in grey stained solid Ash, crystal top.

Pag. 39 - 40

cm. 330 * 120 * h. 72

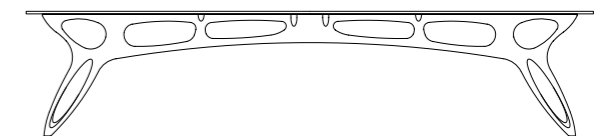
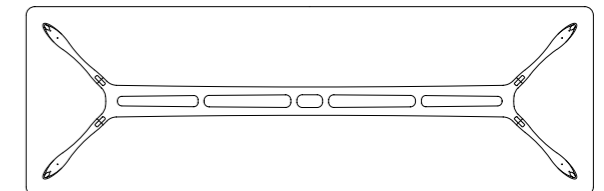

PROMETEO 2018-54

Tavolo rotondo con base in massello di Noce Canaletto finitura opaca, piano in cristallo.
Round table with base in solid Canaletto Walnut matt finished, crystal top.

Pag. 65 - 66

cm. Ø 140 * h. 72

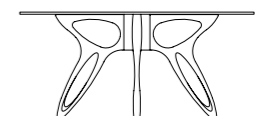
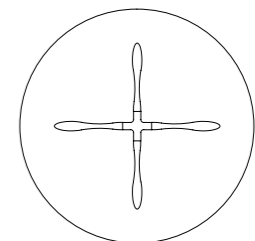

PEGASO 2019-40

Tavolo scultura realizzato in legno massello finitura liquid bronze, piano centrale cristallo.
Sculpture table made in solid wood, liquid-bronze finished, central crystal top.

Pag. 8

cm. Ø 142 * h. 82

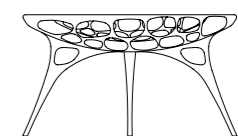
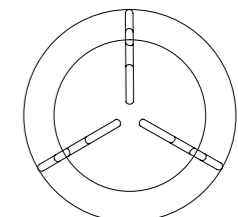

GEA
collection

FEBE 2019-35

Consolle in massello di Frassino tinto grigio
con piano laccato liquid bronze.
*Console in grey stained solid Ash with
top liquid-bronze lacquered.*

Pag. 10 - 13

cm. 140 * 40 * h. 87

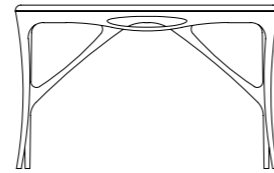

FEBE 2019-36

Specchiera in massello di Frassino tinto grigio.
Mirror in grey stained solid Ash.

Pag. 13

cm. 96 * h. 210

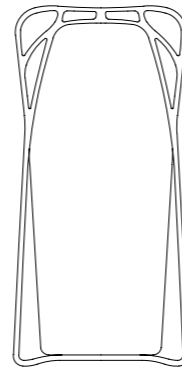

FEBE 2019-37

Specchiera in massello finitura laccata liquid bronze.
Mirror in solid wood, liquid bronze lacquered.

Pag. 10

cm. 96 * h. 210

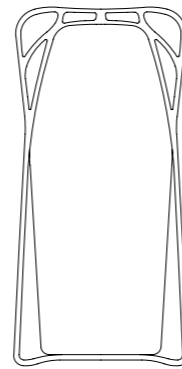

FEBE 2018-65

Sedia in massello di Frassino tinto grigio rivestita in tessuto.
Chair in grey stained solid Ash, covered with fabric.

Pag. 36

cm. 49 * 54 * h. 92

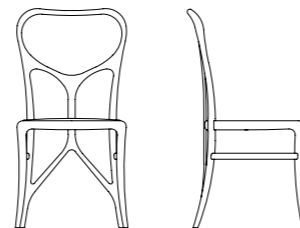

GEA
collection

FEBE 2018-57

Sedia in massello di Noce Canaletto finitura opaca, rivestita in tessuto.
Chair in solid Canaletto Walnut matt finished, covered with fabric.

Pag. 64 - 70

cm. 49 * 54 * h. 92

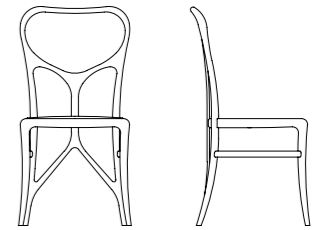

DEMETRA 2018-66

Capotavola in massello di Frassino tinto grigio,
interno rivestito in tessuto, esterno in pelle.
*Chair with arms in grey stained solid Ash,
inside covered with fabric, outside with leather.*

Pag. 39

cm. 60 * 64 * h. 85

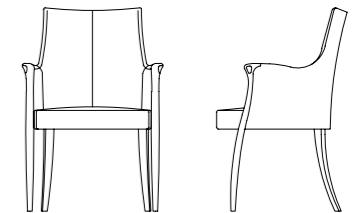

DEMETRA 2018-58

Capotavola in massello di Noce Canaletto finitura opaca,
interno rivestito in tessuto, esterno in pelle.
*Chair with arms in solid Canaletto Walnut matt finished,
inside covered with fabric, outside with leather.*

Pag. 41 - 62

cm. 60 * 64 * h. 85

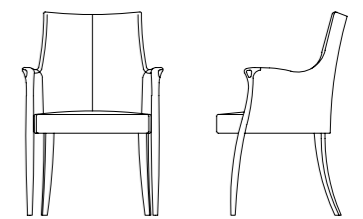

GEA
collection

ARES 2019-02

Divano 2 posti in tessuto. Basamento in essenza di Ziricote con cornice rivestita in pelle. Piedini scultorei in ottone finitura bronzo chiaro opaco.
2 seats sofa covered with fabric. Wooden basement in Ziricote with frame in leather. Sculptural feet in light bronzed matt brass.

Pag. 15 - 20

cm. 192 * 132 * h. 75

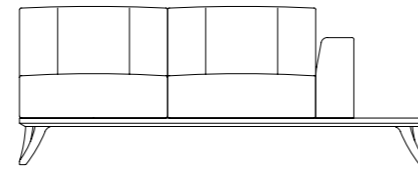

ARES 2019-04

Penisola imbottita in pelle con cuscino schienale in tessuto, basamento in essenza di Ziricote con cornice rivestita in pelle. Piedini scultorei in ottone finitura bronzo chiaro opaco.
Chaise longue for sofa covered in leather with back cushion in fabric, wooden basement in Ziricote with frame in leather. Sculptural feet in light bronzed matt brass.

Pag. 15 - 20

cm. 133 * 132 * h. 75

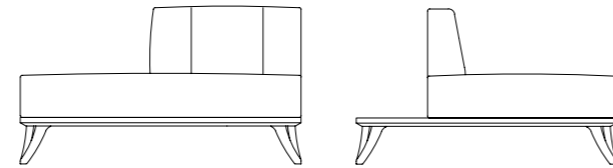

ARES 2019-01

Divano 3 posti imbottito in tessuto con basamento in essenza di Ziricote con cornice rivestita in pelle. Piedini scultorei in ottone finitura bronzo chiaro opaco.
3 seats sofa covered with fabric, wooden basement in Ziricote with frame in leather. Sculptural feet in light bronzed matt brass.

Pag. 19 - 20 - 88

cm. 281 * 132 * h. 75

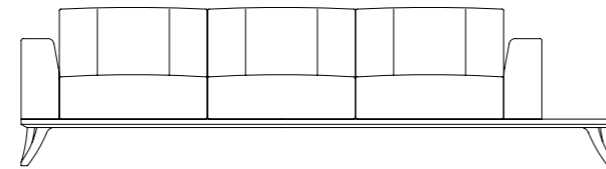

ARES 2019-05

Divano 3 posti imbottito in tessuto con cornice della base rivestita in pelle. Piedini scultorei in ottone finitura bronzo chiaro opaco.
3 seats sofa covered with fabric, base with frame in leather. Sculptural feet in light bronzed matt brass.

Pag. 90

cm. 245 * 98 * h. 75

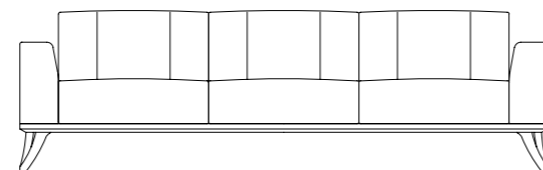

GEA
collection

ARES 2019-03

Penisola imbottita in pelle con cuscino schienale in tessuto, cornice della base rivestita in pelle. Piedini scultorei in ottone finitura bronzo chiaro opaco.
Chaise longue for sofa covered in leather with back cushion in fabric, base with frame in leather. Sculptural feet in light bronzed matt brass.

Pag. 90

cm. 133 * 98 * h. 75

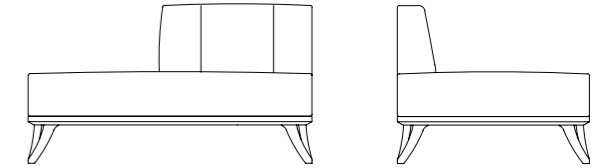

REA 2019-20

Poltrona con struttura in massello di Noce Canaletto finitura opaca, parte interna rivestita in tessuto ed esterna in cuoio.
Armchair in solid Canaletto Walnut matt finished, inside covered with fabric, outside with leather.

Pag. 24 - 26

cm. 92 * 72 * h. 92

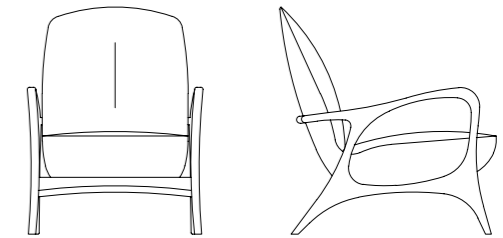

REA 2019-21

Poltrona in massello di Frassino tinto grigio, interno rivestito in tessuto ed esterno in cuoio.
Armchair in grey stained solid Ash, inside covered with fabric, outside with leather.

Pag. 8 - 78 - 106

cm. 92 * 72 * h. 92

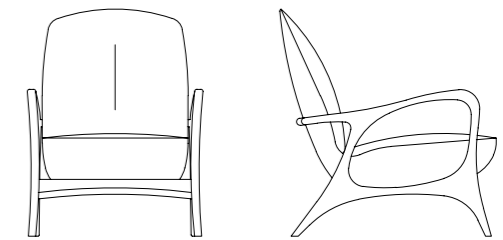

PATAGONIA 2019-25

Tavolino rettangolare base in ottone finitura bronzo opaco chiaro e scuro, piano marmo Silver Wave.
Rectangular coffee table base in light and dark bronzed matt brass, marble top Silver Wave.

Pag. 18 - 20 - 24 - 87

cm. 140 * 60 * h. 26

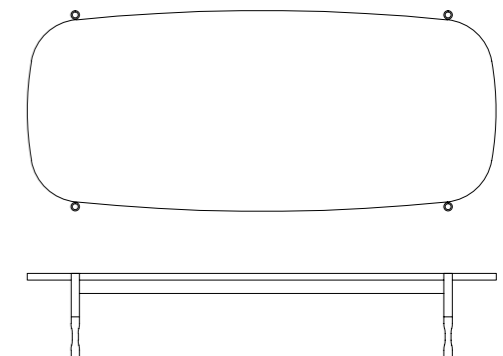

GEA
collection

PATAGONIA 2019-26

Tavolino quadrato base in ottone finitura bronzo opaco chiaro e scuro, piano marmo Calacatta oro.
Square coffee table base in light and dark bronzed matt brass, marble top Calacatta gold.

Pag. 8 - 18 - 20 - 24 - 87

cm. 100 * 100 * h. 34

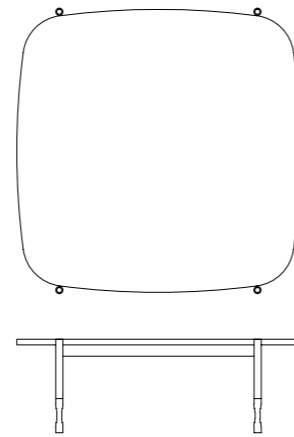

PATAGONIA 2019-10

Tavolino rettangolare base in ottone finitura bronzo opaco chiaro e scuro, piano marmo Calacatta oro.
Coffee table base in light and dark bronzed matt brass, marble top Calacatta gold.

Pag. 92

cm. 130 * 91 * h. 42

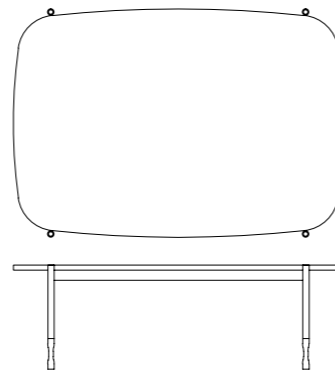

PATAGONIA 2019-11

Tavolino rettangolare base in ottone finitura bronzo opaco chiaro e scuro, piano marmo Patagonia.
Coffee table base in light and dark bronzed matt brass, marble top Patagonia.

Pag. 18 - 21

cm. 130 * 91 * h. 42

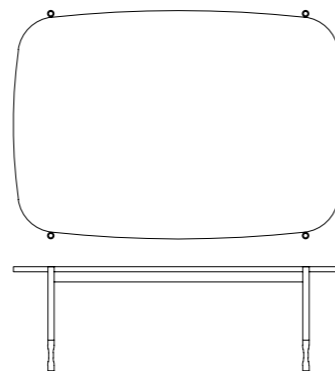

PATAGONIA 2019-12

Tavolino quadrato, struttura in ottone finitura bronzo opaco chiaro e scuro. Piano marmo Patagonia e sottopiano in legno laccato grigio.
Side table base in light and dark bronzed matt brass. Marble top Patagonia and under-top in grey lacquered wood.

Pag. 18 - 21 - 93

cm. 70 * 70 * h. 71

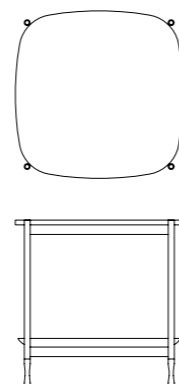

GEA
collection

DEDALO 2019-27

Tavolino con base in massello di Noce Canaletto finitura opaca, piano marmo Calacatta oro.
Small table with base in solid Canaletto Walnut matt finished, marble top Calacatta gold.

Pag. 108

cm. 61 * 61 * h. 63

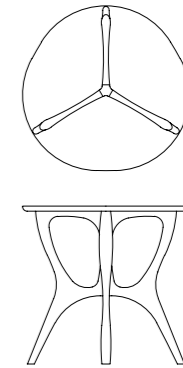

DEDALO 2019-29

Tavolino con base in massello di Noce Canaletto finitura opaca, piano marmo Silver Wave.
Small table with base in solid Canaletto Walnut matt finished, marble top Silver Wave.

Pag. 108

cm. 61 * 61 * h. 63

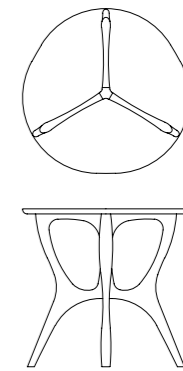

DEDALO 2019-31

Tavolino con base in massello di Noce Canaletto finitura opaca, piano marmo Patagonia.
Small table with base in solid Canaletto Walnut matt finished, marble top Patagonia.

Pag. 24

cm. 61 * 61 * h. 63

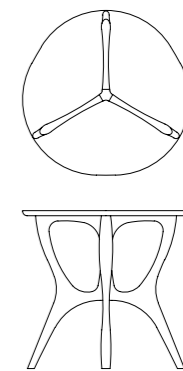

DEDALO 2019-28

Tavolino con base in massello di Frassino tinto grigio e piano in paglia cerata.
Small table with base in solid Ash wood, grey stained finished, stained straw top.

Pag. 78 - 110

cm. 61 * 61 * h. 63

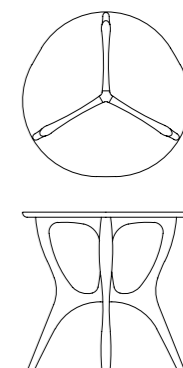

GEA
collection

DEDALO 2019-30

Tavolino con base in massello di Frassino tinto grigio, piano marmo Invisible grey.
Small table with base in solid Ash wood stained grey finished, marble top Invisible grey.

Pag. 109

cm. 61 * 61 * h. 63

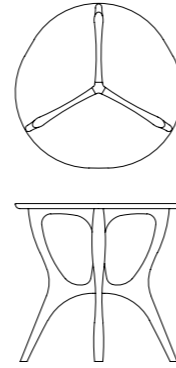

DEDALO 2019-32

Tavolino con base in massello di Frassino tinto grigio, piano marmo Patagonia.
Small table with base in solid Ash wood grey stained finished, marble top Patagonia.

Pag. 48

cm. 61 * 61 * h. 63

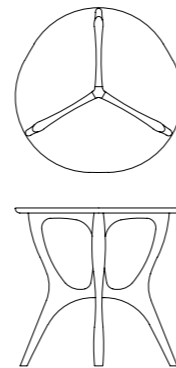

FIDIA 2019-16

Piedistallo in massello di Frassino tinto grigio con piano marmo Calacatta oro.
Pedestal-table in grey stained solid Ash, marble top Calacatta gold.

Pag. 19 - 21

cm. 38 * 38 * h. 122



FIDIA 2019-17

Piedistallo in massello con piano legno, finitura laccata liquid-bronze.
Pedestal-table in solid wood with wooden top, liquid-bronze lacquered.

Pag. 44

cm. 38 * 38 * h. 122



GEA
collection

CRONO 2018-80

Letto in massello di Frassino tinto grigio, testiera imbottita in tessuto con bottoni in essenza e giroletto rivestito in pelle.
Piedini scultorei in ottone finitura bronzo chiaro opaco.
Bed in solid Ash wood grey stained finished. Headboard covered in fabric with buttons in wood and bedframe in leather. Sculptural feet in light bronzed matt brass.

Pag. 47

cm. 236 * 240 * h. 143

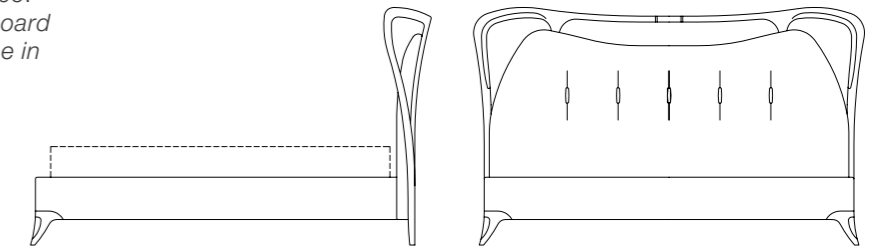

CRONO 2018-70

Letto in massello di Noce Canaletto finitura opaca, testiera imbottita in tessuto con bottoni in essenza e giroletto rivestito in pelle.
Piedini scultorei in ottone finitura bronzo chiaro opaco.
Bed in solid Canaletto Walnut matt finished. Headboard covered in fabric with buttons in wood and bedframe in leather. Sculptural feet in light bronzed matt brass.

Pag. 116 - 118

cm. 236 * 240 * h. 143

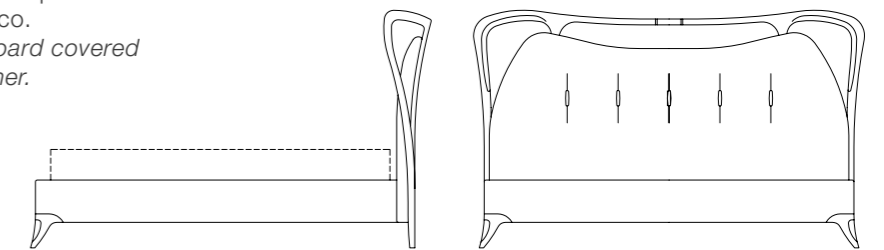

LAPETO 2018-81

Comò con struttura in multistrato impiallacciato in Ebano bianco lucidato poliester, piedini e pomoli scultorei in ottone, finitura bronzo chiaro opaco. Piano marmo Patagonia.
Chest of drawers structure in plywood white Ebony veneered polyester polished. Sculptural feet and knobs in light bronzed matt brass. Marble top Patagonia.

Pag. 46

cm. 120 * 56 * h. 88

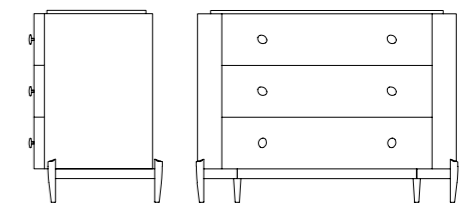

LAPETO 2018-83

Comodino con struttura in multistrato impiallacciato in Ebano bianco lucidato poliester, piedini e pomoli scultorei in ottone, finitura bronzo chiaro opaco. Piano marmo Patagonia.
Night table structure in plywood white Ebony veneered polyester polished. Sculptural feet and knobs in light bronzed matt brass. Marble top Patagonia.

Pag. 47

cm. 65 * 46 * h. 57

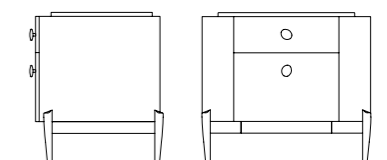

GEA
collection

LAPETO 2018-71

Comò con struttura in multistrato impiallacciato in Noce Canaletto finitura opaca, piedini e pomoli scultorei in ottone, finitura bronzo chiaro opaco. Piano marmo Patagonia.
Chest of drawers structure in plywood Canaletto Walnut veneered matt finished. Sculptural feet and knobs in light bronzed matt brass. Marble top Patagonia.

Pag. 126

cm. 120 * 56 * h. 88

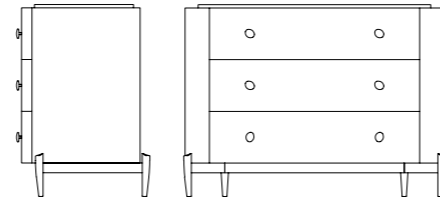

LAPETO 2018-73

Comodino con struttura in multistrato impiallacciato in Noce Canaletto finitura opaca, piedini e pomoli scultorei in ottone, finitura bronzo chiaro opaco. Piano marmo Patagonia.
Night table structure in plywood Canaletto Walnut veneered matt finished. Sculptural feet and knobs in light bronzed matt brass. Marble top Patagonia.

Pag. 121 - 123

cm. 65 * 46 * h. 57

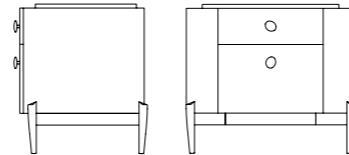

LAPETO 2018-73PL

Comodino con struttura in multistrato impiallacciato in Noce Canaletto finitura opaca, piedini e pomoli scultorei in ottone, finitura bronzo chiaro opaco. Piano legno.
Night table structure in plywood Canaletto Walnut veneered matt finished. Sculptural feet and knobs in light bronzed matt brass. Wooden top.

Pag. 125

cm. 65 * 46 * h. 57

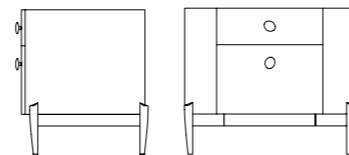

LAPETO 2018-72

Specchiera in legno finitura laccata bronzo.
Mirror with wooden frame bronze lacquered.

Pag. 49 - 127 - 129

cm. 77 * h. 122

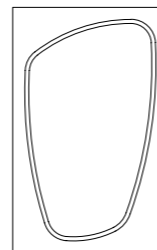

GEA
collection

AFRODITE 2018-84

Consolle trucco, struttura in massello di Frassino tinto grigio con terminali superiori e frontale cassetto in ottone finitura bronzo chiaro opaco. Piano laccato con inserto in pelle.
Vanity structure in solid Ash wood, grey stained finished with upper elements and front of drawer in light bronzed matt brass. Lacquered top with leather insert.

Pag. 49

cm. 125 * 46 * h. 76

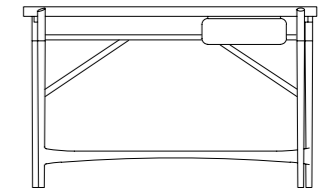

AFRODITE 2018-74

Consolle trucco, struttura in massello di Noce Canaletto finitura opaca con terminali superiori e frontale cassetto in ottone finitura bronzo chiaro opaco. Piano laccato con inserto in pelle.
Vanity structure in solid Canaletto Walnut matt finished with upper elements and front of drawer in light bronzed matt brass. Lacquered top with leather insert.

Pag. 130

cm. 125 * 46 * h. 76

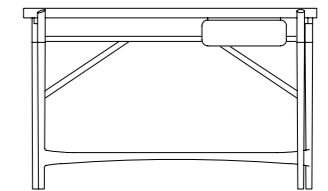

AFRODITE 2018-77

Pouf imbottito in tessuto e pelle con piedini in ottone finitura bronzo chiaro opaco.
Pouf covered with fabric and leather, feet in light bronzed matt brass.

Pag. 49 - 130 - 132

cm. 60 * 47 * h. 45

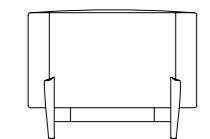

AFRODITE 2018-75

Specchiera in ottone finitura bronzo chiaro opaco con vassoio in marmo Calacatta oro.
Vanity mirror in light bronzed matt brass with marble tray Calacatta gold.

Pag. 49 - 130

cm. 30 * 20 * h. 46

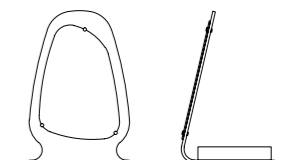

GEA
collection

SELENE 2018-76

Dormeuse imbottita in tessuto e pelle con piedini in ottone finitura bronzo chiaro opaco.
Dormeuse covered with fabric and leather, feet in light bronzed matt brass.

Pag. 48 - 133

cm. 182 * 97 * h. 74

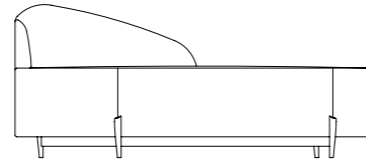

ATENA 2018-44

Specchiera con struttura in ottone finitura bronzo chiaro opaco.
Mirror with structure in light bronzed matt brass.

Pag. 46 - 73 - 74

cm. 153 * h. 100

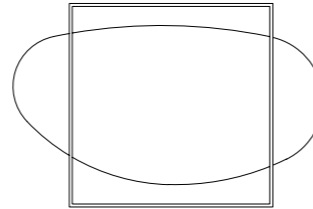

CABINA ARMADIO_WALK-IN CLOSET

AFRODITE 2018-95EA

Elemento con ante rivestite in pelle con trapuntature geometriche, maniglia scultorea in ottone finitura nichel scuro.
Element with doors covered in leather with geometric padding. Sculptural handles in dark nichel brass.

Pag. 56

cm. 120 * 60 * h. 307

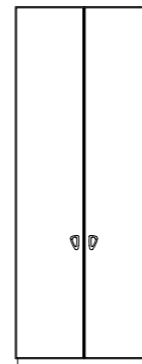

AFRODITE 2018-95EP

Elemento a giorno con 3 cassetti in frassino tinto grigio. *Ripiani in vetro e schienale rivestito in tessuto con elementi in ottone finitura nichel scuro.*
Element without door with 3 drawers in grey stained Ash, upper part with crystal shelves and back covered in fabric with dark nichel brass.

Pag. 58

cm. 87 * 60 * h. 307



GEA
collection

AFRODITE 2018-95EG

Elemento a giorno con 6 cassetti in frassino tinto grigio, *ripiani in vetro e schienale rivestito in tessuto con elementi in ottone finitura nichel scuro.*
Element without door with 6 drawers in grey stained Ash, upper part with crystal shelves and back covered in fabric with dark nichel brass.

Pag. 56

cm. 204 * 60 * h. 307

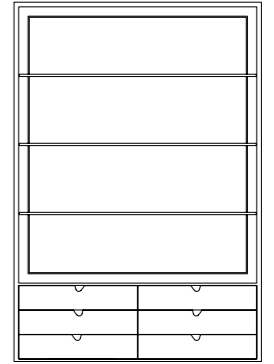

AFRODITE 2018-95EV

Elemento con 3 cassetti in frassino tinto grigio e parte superiore con anta vetro e maniglia scultorea in ottone finitura nichel scuro, ripiani in vetro e legno con schienale rivestito in tessuto.
Element with 3 drawers in grey stained Ash, upper part with crystal door and sculptural handle in dark nichel brass. Crystal and wooden shelves, back covered in fabric.

Pag. 56

cm. 60 * 60 * h. 307

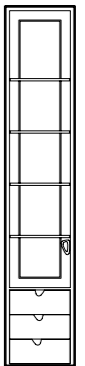

AFRODITE 2018-95EM

Elemento vano a giorno con schienale in marmo Silver Wave retro-illuminato, con elementi in ottone finitura nichel scuro.
Element without door with backlit Silver Wave marble and dark nichel brass.

Pag. 54

cm. 87 * 35 * h. 307



AFRODITE 2018-94

Pouf rivestito in pelle con piedini in ottone finitura nichel scuro.
Pouf covered with leather, feet in dark nichel brass.

Pag. 56

cm. 110 * 110 * h. 45

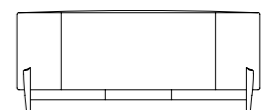

STONE 2019-50

Poltrona imbottita in tessuto, inserto frontale in legno laccato grigio.
Armchair upholstered with fabric, wooden frontal inserts grey lacquered.
Pag. 134

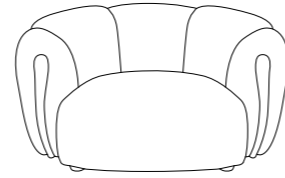

cm. 125 * 105 * h. 68

STONE 2019-51

Pouf imbottito in tessuto.
Pouf covered in fabric.
Pag. 134

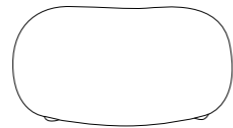

cm. 90 * 60 * h. 35

STONE 2019-52

Divano imbottito in tessuto, inserto frontale in legno laccato grigio.
Sofa upholstered with fabric, wooden frontal inserts grey lacquered.
Pag. 134

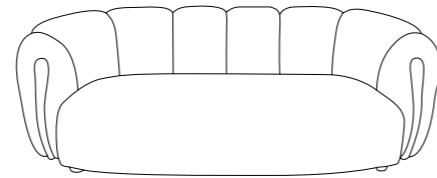

cm. 220 * 105 * h. 68

EGEO 2019-55

Poltrona con profili ed imbottitura in tessuto.
Parte interna in capitonnè.
Armchair with piping and covering in fabric.
Inside worked capitonnè.
Pag. 138

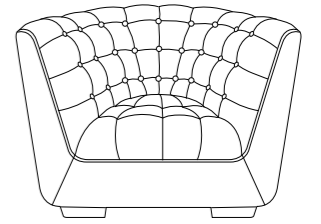

cm. 110 * 90 * h. 80

EGEO 2019-57

Divano 3 posti con profili ed imbottitura in tessuto.
Parte interna in capitonnè.
3 seats sofa with piping and covering in fabric.
Inside worked capitonnè.
Pag. 139

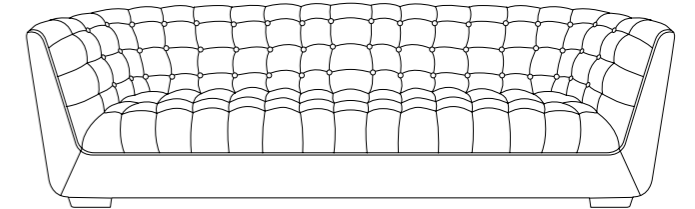

cm. 270 * 90 * h. 80

EGEO 2019-58

Divano ad angolo con profili ed imbottitura in tessuto.
Parte interna in capitonnè.
Corner sofa with piping and covering in fabric.
Inside worked capitonnè.
Pag. 140

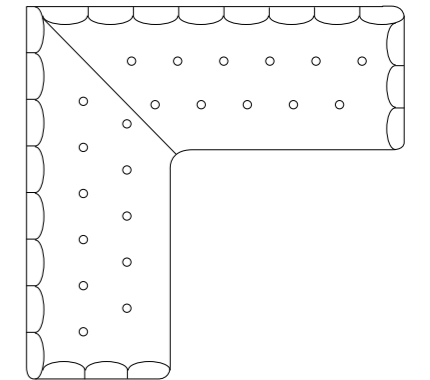

cm. 270+270 * 90 * h. 80

DELFI
collection

Technical information

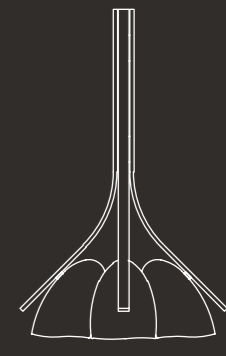
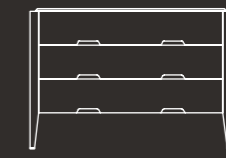
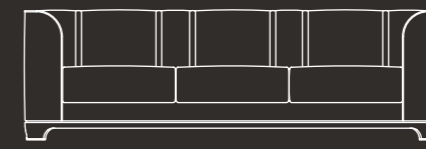

DELFI
collection

AURIGA 2018-20

Moblie 4 ante con struttura in multistrato, ante in mdf impiallacciato in Frassino finitura urban black con base in massello di Frassino laccata bronzo. Piano in marmo Calacatta oro.
Sideboard 4 doors in plywood, doors in MDF veneered Ash urban black finished with base in Ash wood bronze lacquered. Marble top Calacatta gold.

Pag. 162- 164

cm. 197 * 48 * h. 91

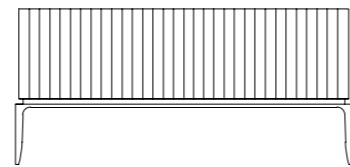

AURIGA 2018-19

Moblie 4 ante con struttura in multistrato, ante in mdf impiallacciato in Frassino tinto grigio, base in massello di Frassino laccata nero opaco. Piano in marmo Calacatta oro.
Sideboard 4 doors in plywood, doors in MDF veneered Ash stained grey finished with base in Ash wood matt black lacquered. Marble top Calacatta gold.

Pag. 184

cm. 197 * 48 * h. 91

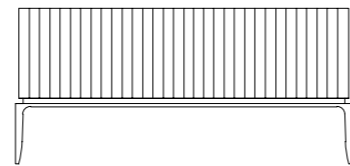

AURIGA 2018-21

Vetrina con struttura in multistrato, spalle e cassetto in mdf impiallacciato in Frassino, finitura urban black con base in massello di Frassino, finitura laccata bronzo. Ripiano centrale in marmo Calacatta oro, luci a led interne.
Glass cabinet in plywood, sides and drawer in MDF veneered Ash urban black finished and base in Ash wood stained grey finished. Central shelf in marble Calacatta gold, led lights inside.

Pag. 170

cm. 215 * 52 * h. 211

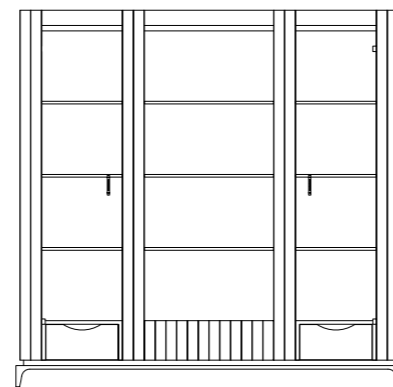

AURIGA 2018-28

Moblie bar con struttura in multistrato, ante in mdf impiallacciato in Frassino finitura moka brown e base in massello di Frassino laccata nero opaco. Interno con cassetti, ripiani e luci a led.
Bar cabinet in plywood, doors in MDF veneered Ash moka brown finished and base in Ash wood matt black lacquered. Inside with drawers, shelves and led lights.

Pag. 214

cm. 112 * 52 * h. 185

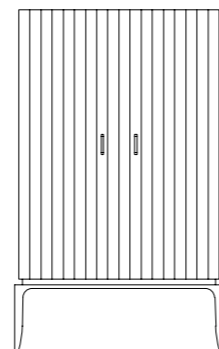

DELFI
collection

AURIGA 2018-24

Consolle con struttura in mdf impiallacciata in Frassino, finitura urban black. Base in massello di Frassino laccata bronzo, completa di "briglie" in ottone finitura bronzo scuro opaco. Piano in marmo Calacatta oro.
Console in MDF veneered Ash urban black finished. Base in Ash wood bronze lacquered complete of "bridles" in dark bronzed matt brass. Marble top Calacatta gold."

Pag. 147

cm. 130 * 47 * h. 92

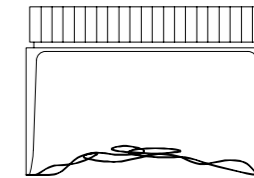

AURIGA 2018-25

Specchiera in mdf impiallacciata in Frassino laccata bronzo.
Mirror in MDF veneered Ash, bronze lacquered.

Pag. 147 - 148

cm. 84 * h. 84

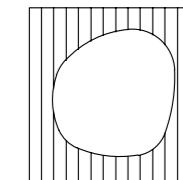

AURIGA 2018-22

Moblie bar con struttura in mdf impiallacciata in Frassino tinto grigio base in massello di Frassino laccata nero opaco, completa di "briglie" in ottone finitura bronzo chiaro opaco.
Bar cabinet in MDF veneered Ash stained grey finished, base in Ash wood matt black lacquered complete of decorative "bridles" in light bronzed matt brass.

Pag. 186

cm. 113 * 53 * h. 166

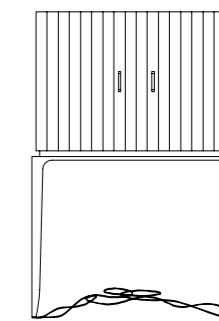

AURIGA 2018-23

Moblie bar con struttura in mdf impiallacciata in Radica Ferrarese, finitura lucida spazzolata con base in massello di Frassino laccata nero opaco, completa di "briglie" in ottone finitura bronzo chiaro opaco.
Bar cabinet in MDF veneered briarwood "Ferrarese", brushed shiny finished base in Ash wood matt black lacquered complete of decorative "bridles" in light bronzed matt brass.

Pag. 216

cm. 113 * 53 * h. 166

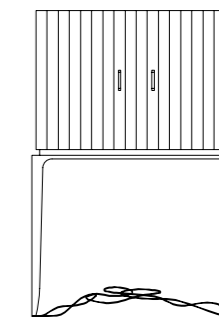

DELFI
collection

AURIGA 2018-30

Tavolo rettangolare in massello di Frassino finitura urban black con fascia laccata bronzo. Piano in Quartzite Green Botanique.
Rectangular table in Ash wood urban black finished with part under top bronze lacquered. Top in Quartzite Green Botanique.

Pag. 156 - 158

cm. 230 * 110 * h. 76

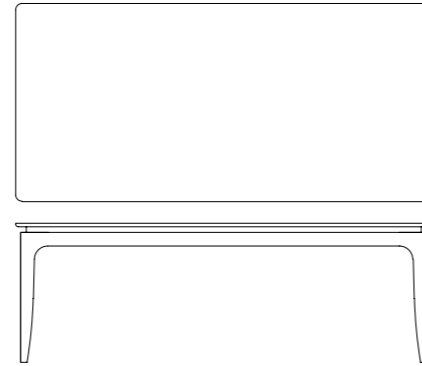

AURIGA 2018-31

Tavolo rettangolare in massello di Frassino finitura urban black con fascia laccata bronzo. Piano in marmo bianco Carrara.
Rectangular table in Ash wood urban black finished with part under top bronze lacquered. Marble top white Carrara.

Pag. 166 - 168

cm. 300 * 120 * h. 76

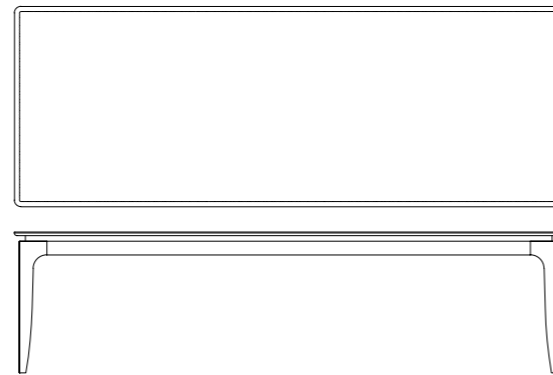

FICUS 2016-42

Tavolo rotondo in massello di Tiglio intagliato finitura nichel scuro, piano in cristallo.
Round table in Lime wood black nichel lacquered, crystal top.

Pag. 172 - 174

cm. Ø 160 * h. 76

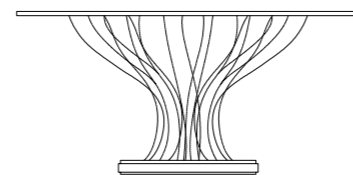

ICO 2018-32

Sedia in massello di Frassino finitura urban black, rivestita in tessuto.
Chair in Ash wood urban black finished, covered with fabric.

Pag. 156 - 160 - 166 - 168 - 174 - 176

cm. 54 * 57 * h. 95

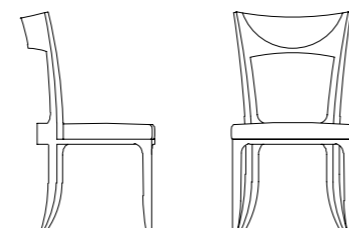

DELFI
collection

OMERO 2018-09

Specchiera in massello di Tiglio laccata nichel scuro.
Mirror in Lime wood black nichel lacquered.

Pag. 151

cm. 91 * 17 * h. 135

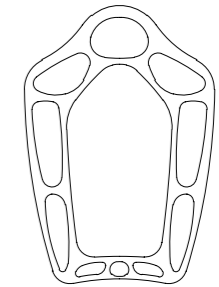

OMERO 2018-08

Consolle in massello di Tiglio laccata nichel scuro. Piano in marmo Nero Assoluto.
Console in Lime wood black nichel lacquered. Marble top Total Black.

Pag. 151

cm. 128 * 48 * h. 96

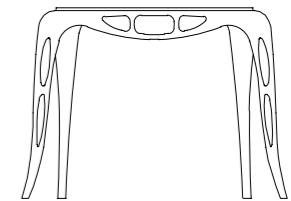

OMERO 2018-07

Specchiera in massello di Tiglio laccata liquid-bronze.
Mirror in Lime wood liquid bronze lacquered.

Pag. 152

cm. 91 * 17 * h. 135

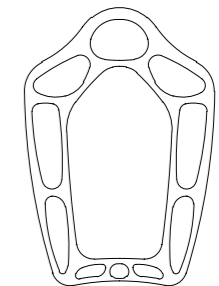

OMERO 2018-06

Consolle in massello di Tiglio laccata liquid-bronze. Piano in marmo Nero Portoro.
Console in Lime wood liquid bronze lacquered. Marble top Portoro black.

Pag. 152

cm. 128 * 48 * h. 96

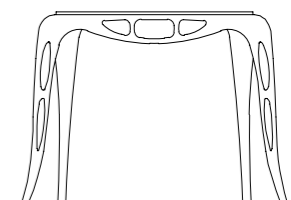

DELFI
collection

2016-46

Divano 3 posti imbottito in tessuto con particolari in pelle con basamento in massello di Frassino finitura urban black.
3 seats sofa covered with fabric and details in leather, in Ash wood urban black finished.

Pag. 180 - 209

Opzione: imbottito in tessuto con particolari in pelle, basamento in massello di Frassino finitura Moka Brown.
Option: covered in fabric and details in leather, wooden basement in Ash wood moka brown finished.

Pag. 190

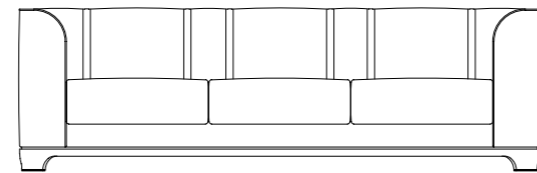

cm. 260 * 108 * h. 78

2018-17

Sistema di sedute, imbottitura in microfibra con particolari in pelle. Basamento in massello di Frassino finitura urban black.
Modular sofa system, covering in microfiber and details in leather. Wooden basement in Ash wood urban black finished.

Pag. 187

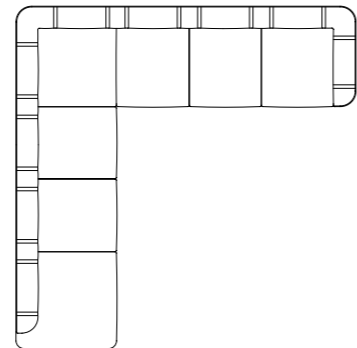

cm. 340+350 * 108 * h. 78

AURIGA 2018-18

Pouf imbottito in microfibra con particolari in pelle. Basamento in massello di Frassino finitura urban black.
Pouf covered in microfiber and details in leather. Basement in Ash wood urban black finished.

Pag. 187



cm. 130 * 90 * h. 45

DELFI
collection

ATTESA 2018-10

Poltrona in massello di Frassino finitura urban black.
Armchair in Ash wood urban black finished.

Pag. 182 - 202

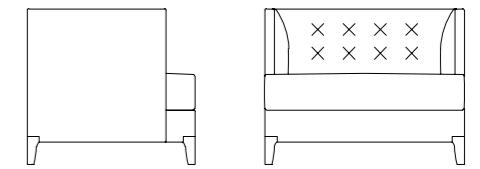

cm. 93 * 87 * h. 73

TESEO 2018-13

Poltrona in massello di Frassino finitura moka brown, rivestita in tessuto.
Armchair in Ash wood moka brown finished, covered in fabric.

Pag. 191

Opzione: in massello di Frassino finitura urban black
Option: Ash wood urban black finished

Pag. 204 - 235

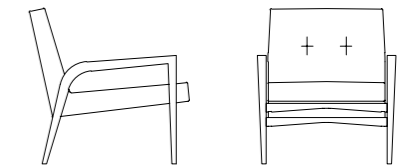

cm. 73 * 77 * h. 78

MEDITA 2018-01

Poltrona imbottita, piedini in finitura urban black.
Upholstered armchair, feet urban black finished.

Pag. 168 - 198

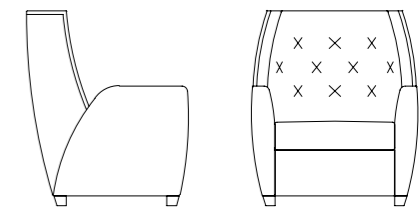

cm. 90 * 88 * h. 108

MEDITA 2018-02

Poltrona con basamento girevole imbottita in pelle nabuk.
Armchair with swivel base, upholstered with nabuk leather.

Pag. 197

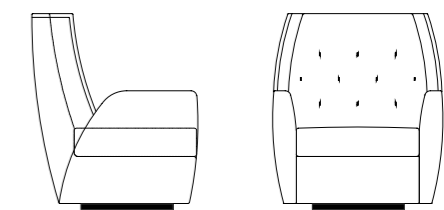

cm. 90 * 88 * h. 111

DELFI
collection

PLEIADI 2018-03

Tavolino quadrato, piano in multistrato impiallacciato e parti in massello di Frassino, finitura urban black. Piano con alzate in ottone finitura bronzo chiaro opaco e piani in Quartzite Green Botanique.

Square coffee table, top in plywood veneered and parts in Ash wood, urban black finished. Brass trays light bronzed matt finishing and Quartzite Green Botanique tops.

Pag. 194

Opzione: finitura moka brown - piani in Onice Orange

Option: moka brown finishing - Onyx Orange tops

Pag. 190

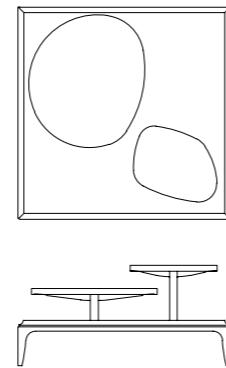

cm. 110 * 110 * h. 25/55

PLEIADI 2018-04

Tavolino quadrato, top in multistrato impiallacciato e parti in massello di Frassino, finitura urban black.

Square coffee table, top in plywood veneered and parts in Ash wood, urban black finished.

Pag. 182

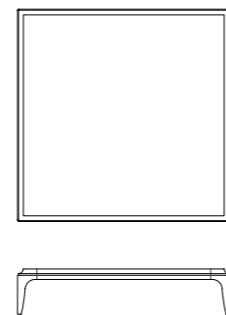

cm. 110 * 110 * h. 25

MILETO 2018-14

Tavolino quadrato, piani in multistrato impiallacciato con parti in massello di Frassino, finitura urban black. Insetto in Sodalite sul centro del piano.

Square coffee table, tops in plywood veneered and parts in Ash wood, urban black finished. Central part in Sodalite stone.

Pag. 180 - 211

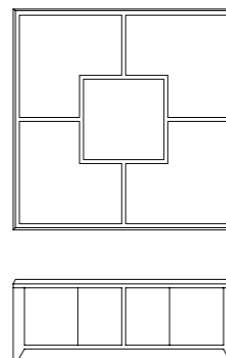

cm. 110 * 110 * h. 41

DELFI
collection

MILETO 2018-16

Tavolino quadrato in multistrato con parti in massello di Frassino, finitura urban black.

Side table, tops in plywood veneered and parts in Ash wood, urban black finished.

Pag. 211

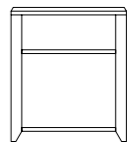
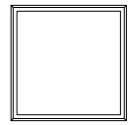

cm. 60 * 60 * h. 71

2016-49

Tavolino rotondo, piano in multistrato impiallacciato in Ebano, basamento in ottone lucido.

Side table, top in plywood veneered Ebony and base in bright brass.

Pag. 183

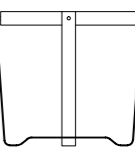
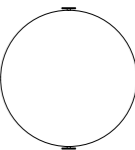

cm. Ø 73 * h. 69

2018-05

Tavolino ovale in multistrato impiallacciato con parti in massello di Frassino, finitura urban black. Piano in marmo Rosso Lepanto.

Oval coffee table in plywood veneered and parts in Ash wood, urban black finished. Marble top Red Lepanto.

Pag. 235

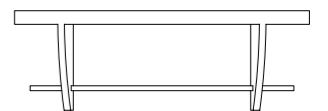
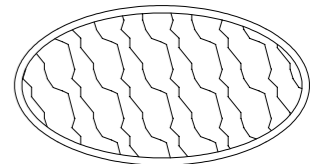

cm. 120 * 65 * h. 40

DELFI
collection

LEVANTE 2017-36

Letto a baldacchino con struttura in massello di Frassino finitura urban black. Cimasa in ottone finitura bronzo chiaro opaco, testata rivestita in pelle nabuk capitonnè con bottoni gioiello.

Canopy bed in Ash wood, urban black finished. Coping in light bronzed matt brass, headboard covered in nabuk leather and capitonnè with jewel buttons.

Pag. 222

Opzione: rivestimento in pelle

Option: covering with leather

Pag. 234

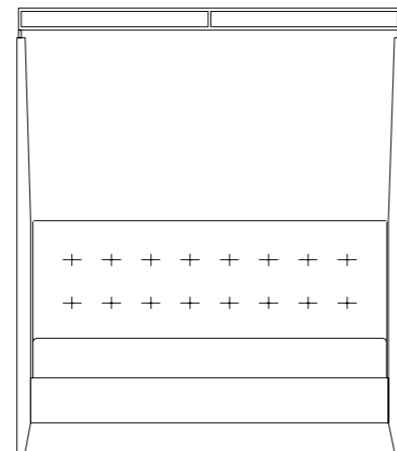

cm. 213 * 222 * h. 227

LEPANTO 2017-31

Comodino in multistrato impiallacciato con parti in massello di Frassino finitura urban black. Cassetto rivestito in pelle nabuk ed interni in Acero tinto grigio. Maniglia e puntali in ottone finitura bronzo chiaro opaco. Piano in marmo Rosso Lepanto.

Bedside table in plywood veneered and parts in Ash wood, urban black finished. Drawer covered in nabuk leather and inside in gray dyed Maple. Handle and end-feet in light bronzed matt brass. Marble top Red Lepanto.

Pag. 224

Opzione: Cassetto rivestito in pelle.

Maniglia e puntali in ottone finitura bronzo scuro opaco.

Option: Drawer covered in leather.

Handle and end-feet in dark bronzed matt brass.

Pag. 234

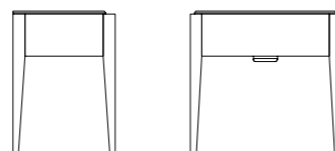

cm. 70 * 51 * h. 68

DELFI
collection

LEPANTO 2017-32

Comò in multistrato impiallacciato con parti in massello di Frassino finitura urban black, cassetti rivestiti in pelle nabuk, dettagli e puntali in ottone finitura bronzo chiaro opaco.

Chest of drawers in plywood veneered and parts in Ash wood urban black finished. Drawers covered in nabuk leather and inside in grey dyed Maple. Details and end-feet in light bronzed matt brass. Marble top Red Lepanto.

Pag. 226

cm. 125 * 54 * h. 88

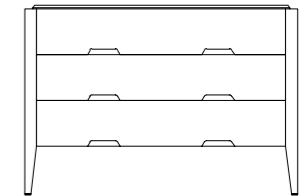

LEPANTO 2018-27

Specchiera in multistrato impiallacciato con parti in massello di Frassino finitura urban black. Dettagli in ottone finitura bronzo chiaro opaco.

Mirror in plywood veneered and parts in Ash wood, urban black finished. Details in light bronzed matt brass.

Pag. 226

cm. 87 * h. 105

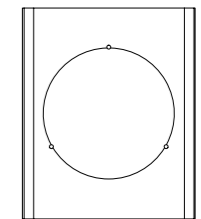

FRINE 2017-33

Consolle trucco con struttura in multistrato impiallacciato con parti in massello di Frassino finitura urban black. Contenitore centrale a ribalta in finitura laccata bronzo, alloggiamenti interni in Acero tinto grigio. Puntali in ottone finitura bronzo chiaro opaco.

Vanity in plywood veneered and parts in Ash wood, urban black finished. Central flap compartment bronze lacquered, inside housing in grey dyed Maple. End-feet in light bronzed matt brass.

Pag. 229

cm. 135 * 51 * h. 75

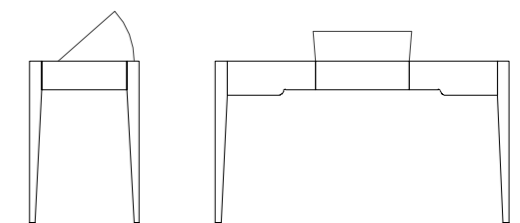

FRINE 2017-42

Pouf imbottito in pelle nabuk con capitonnè e bottoni gioiello, base in massello di Frassino finitura urban black.

Pouf upholstered in nabuk leather and jewel buttons, base in Ash wood urban black finished.

Pag. 229

cm. 47 * 47 * h. 45

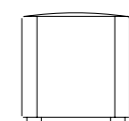

FRINE 2017-43

Panchetta in massello di Frassino finitura urban black, rivestita in tessuto.
Bench in Ash wood urban black finish, covered in fabric.
Pag. 222 - 234

cm. 130 * 52 * h. 46

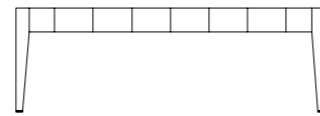

NAXOS 2017-48

Armadio a due ante con struttura in multistrato impiallacciato e parti in massello di Frassino, finitura urban black. Interni attrezzati con cassetti, appenderia e portaoggetti. Cassetti rivestiti in pelle nabuk con interni in Acero tinto grigio. Dettagli in ottone finitura bronzo chiaro opaco.
Double shutter wardrobe in plywood veneered and parts in Ash wood, urban black finished. Equipped with drawers, hangers and trays. Drawers covered with nabuk leather and inside in gray dyed Maple.
Details in light bronzed matt brass.

Pag. 230 - 232
cm. 130 * 70 * h. 210

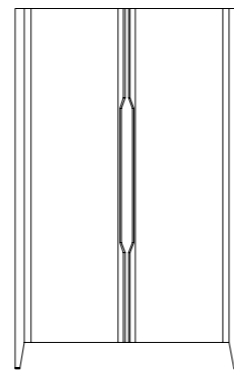

GLI ELM1 01 | Applique

Applique con struttura in ferro crudo e vetro di Murano colorato grigio medio. Attacco lampadina E27.
Wall light with raw iron structure and Murano glass medium grey coloured E27 light socket.
Pag. 241

cm. 25 * 41 * h. 65



GLI ELM1 03 | 3 lights chandelier

Lampadario a 3 luci con struttura in ferro crudo e vetro di Murano colorato grigio medio. Attacco lampadina E27.
3 lights chandelier with raw iron structure and Murano glass medium grey coloured. E27 light socket.
Pag. 240

cm. Ø 50 * h. 70

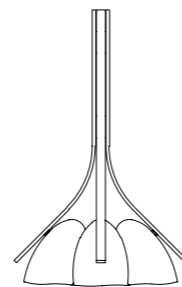

GLI ELM1 06 | 6 lights chandelier

Lampadario a 6 luci con struttura in ferro crudo e vetro di Murano colorato grigio medio. Attacco lampadina E27.
6 lights chandelier with raw iron structure and Murano glass medium grey coloured. E27 light socket.
Pag. 238

cm. 112 * 60 * h. 80

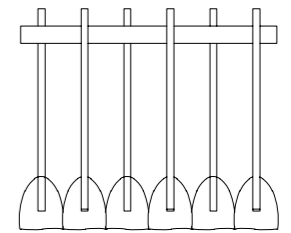

GLI ELM1 09 | 9 lights chandelier

Lampadario a 9 luci con struttura in metallo bronzato e vetro di Murano colorato ametista. Attacco lampadina E27.
9 lights chandelier with bronzed structure and Murano glass Amethyst coloured. E27 light socket.
Pag. 242

cm. Ø 80 * h. 70

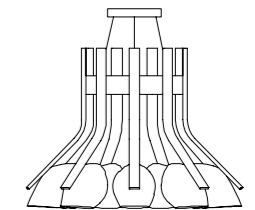

GLI ELM1 10 | Night table lamp

Lumetto da comodino con struttura in metallo bronzato e vetro di Murano colorato. Attacco lampadina E27.
Night table lamp with bronzed structure and coloured Murano glass. E27 light socket.

Pag. 219 Color Ametista / Amethyst coloured
Pag. 243 Colore Ambra / Amber coloured

cm. Ø 22 * h. 45

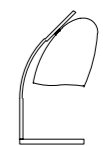

GLI ACHEI 11 | Pendant

Elemento illuminante con struttura in metallo finitura canna di fucile e vetro di Murano colorato grigio medio. Attacco lampadina E27.
Pendant chandelier with gunmetal coloured structure and Murano glass medium grey coloured. E27 light socket.
Pag. 244

cm. Ø 20 * 220-190 * h. 160





by Bellotti Ezio

I colori dei legni, delle laccature, dei tessuti e delle pelli presenti in questo catalogo sono suscettibili dei procedimenti di stampa. Fa fede il campionario dell'azienda. Bellotti Ezio Arredamenti si riserva la facoltà di modificare in qualunque momento e senza preavviso le caratteristiche tecniche (misure, finiture, tessuti e pelli) dei suoi prodotti.

Woods, lacquers, fabrics and leathers color as showed in this catalog are not always reliable due to printing effects, simply refer to the company sample. Bellotti Ezio Arredamenti reserves the right to modify the technical specifications of the products (size, finishing, leather and fabric) featured in at any time and without prior notice.

Bel Mondo by Bellotti Ezio
Via Milano ang. Via Buozzi 22060 - Cabiato (Co) - Italy
Tel. (39) 031 766113 - www.belmondobybellotti.it - bellotti@bellotti.it